



New active current sensors for maximum accuracy

- Closed – loop sensors, using a patented soft – magnetic probe as the zero – field detector.
- three new type series for rated currents of 6 A to 100 A and peak currents up to ± 200 A in compact designs
- types for + 5 Volt power supply with voltage output. optionally internal or external reference voltage
- types for +/- 12 ... 15 Volt power supply with current output
- very good measuring accuracy, minimum DC offset with very low hysteresis
- negligible output noise or periodic signal at zero input
- very low temperature dependence and long-term drift of the output variable
- low rise time, wide frequency range
- low-cost constructions
- compatible dimensions and pinning
- VDE- and UL –approvals under preparation
- new reflow – solderable types (paste-to-pin)

Three new VAC current sensor series

VAC offers 3 new current sensor series for PCB mounting in which electronics and primary conductors are integrated.

The patented VAC principle of the closed – loop sensor with magnetic probe as a zero field detector is distinguished by maximum precision of the current detection. The electronics of the new VAC current sensors are concentrated almost entirely in a new IC, which is a common development with a leading semiconductor manufacturer.

Some of the new types are smaller than previous VAC sensors but all of them offer the detection of high maximum and continuous currents. The new VAC sensors can be used 1:1 in many customer applications without adaptations.

Typical applications

- Variable speed drives
- Uninterruptable power supplies
- Welding inverters
- Switched mode power supplies
- Photovoltaics





Type series of new VAC current sensors

Item no. Type T6040-N...		rated current	Max. meas. range $I_{P,max.} @ V_C = +5 V$ or $V_C = +15 V$	ambient temp. range T_{amb}	supply voltage	turns ratio K_N	Output variable	$V_{ref} - In / output^2$	frequency range	accuracy X @ I_{PN} ; $T_{amb} = 25 °C$	Primary-connection		Secondary conn.	Integrated Electronics	Encapsulated	Dimensional diagrams	
		[A]		[°C] -40 to	[V]				[kHz] DC to		[%]	Plins					Opening
	4646-X653	6	± 20	+ 85	+ 5	(1 ... 3): 2000	U		100	0,7	1	
	4646-X673 ¹																
	4646-X652	15	± 51	+ 85	+ 5	(1 ... 3): 2000	U		100	0,7	1	
	4646-X672 ¹																
	4646-X651	25	± 85	+ 85	+ 5	(1 ... 3): 2000	U		100	0,7	1	
	4646-X671 ¹																
	4646-X654	50	± 150	+ 85	+ 5	(1 ... 3): 1400	U		100	0,7	1	
4646-X674 ¹																	
	4646-X663 ²	6	± 20	+ 85	+ 5	(1 ... 3): 2000	U	.	100	0,7	2	
	4646-X683 ^{1,2}																
	4646-X662 ²	15	± 51	+ 85	+ 5	(1 ... 3): 2000	U	.	100	0,7	2	
	4646-X682 ^{1,2}																
	4646-X661 ²	25	± 85	+ 85	+ 5	(1 ... 3): 2000	U	.	100	0,7	2	
	4646-X681 ^{1,2}																
	4646-X664 ²	50	± 150	+ 85	+ 5	(1 ... 3): 1400	U	.	100	0,7	2	
4646-X684 ^{1,2}																	
	4646-X300	25 30 50	± 85 ± 86 ± 88	+ 85 + 70 + 50	± 12 ... 15	(1 ... 5): 1000	I		100	0,5	3	
	4646-X400	25	± 75	+ 85	± 12 ... 15	(1 ... 3): 1000	I		100	0,5	4	
	4646-X410	50	± 125	+ 85	± 12 ... 15	(1 ... 3): 1000	I		100	0,5	4	
	4646-X412	100	± 160	+ 85	± 12 ... 15	(1 ... 3): 2000	I		100	0,5	4	
	4646-X413	100	± 200	+ 85	± 12 ... 15	(1 ... 3): 1500	I		100	0,5	4	
	4646-X460 ²	50	± 150	+ 85	+ 5	(1 ... 3): 1400	U	.	100	0,7	5	
	4646-X461 ²	100	± 200	+ 85	+ 5	(1 ... 3): 1100	U	.	100	0,7	5	

Abbreviations and terms

(1) reflow – solderable type

(2) reference voltage input 0 ... 3 V, also to be used as reference voltage output 2,5 ± 0,005 V. Source resistance Ri = 680 Ohm.

$I_{PN,rms} @ K_N = 1:N$

$I_{P,max.} @ V_C = ... V$

T_A

V_C

K_N

f

X @ $I_{PN} T_a = 25 °C$

[A] primary rated current

[A] maximum measuring range

[°C] ambient temperature

[V] supply voltage

turns ratio

[kHz] frequency range

[%] accuracy



Dimensional diagrams

Diagram no. 1

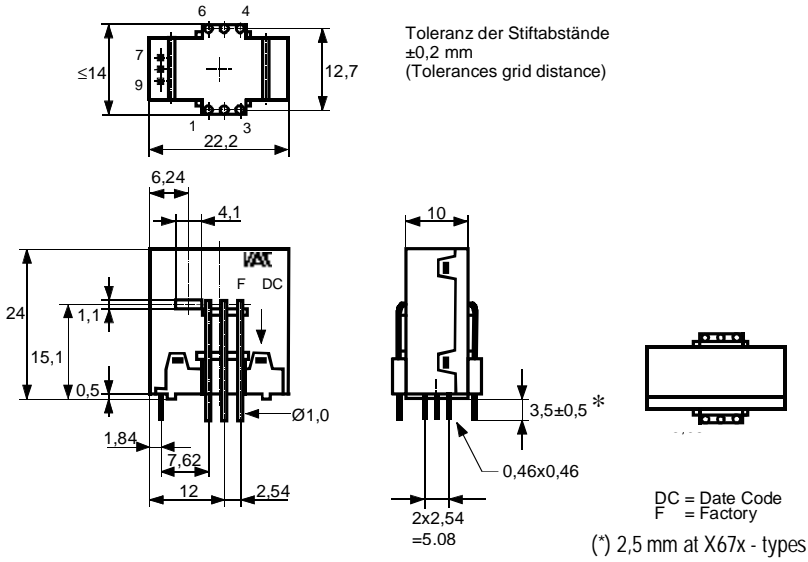

Type

T60404-N4646-X651 and ...X671
T60404-N4646-X652 and ...X672
T60404-N4646-X653 and ...X673
T60404-N4646-X654 and ...X674

Diagram no. 2

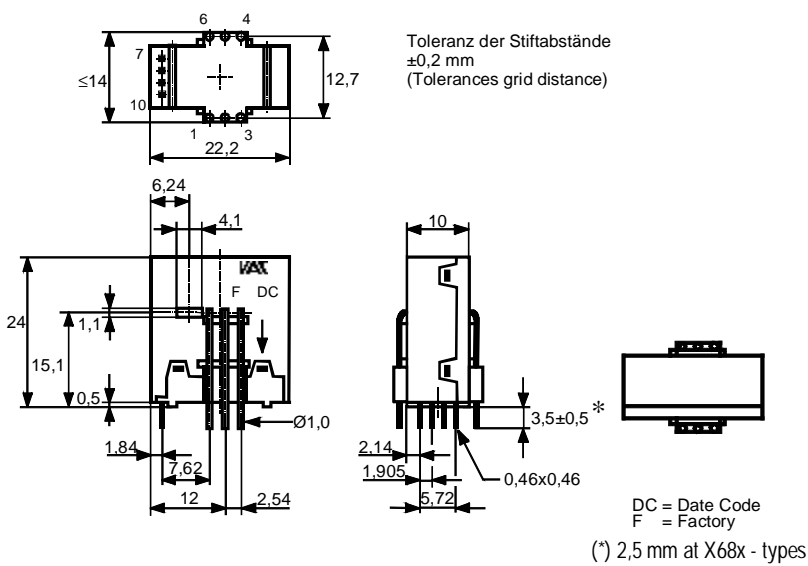

Type

T60404-N4646-X661 and ...X681
T60404-N4646-X662 and ...X682
T60404-N4646-X663 and ...X683
T60404-N4646-X664 and ...X684



Diagram no. 3

Toleranz der Stiftabstände $\pm 0,3\text{mm}$
(Tolerances grid distance)

Stift Nr.1-10 = $\varnothing 1,0$
Nr.11,12,13 = $0,88 \times 0,60$

Ziffern 1 - 13 nicht aufgedruckt
Numbers 1 - 13 not imprinted

Type

T60404-N4646-X300

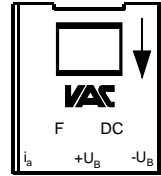
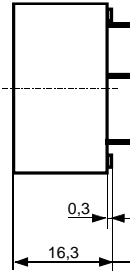
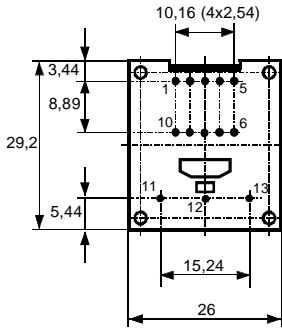

DC = Date Code
F = Factory



Diagram no. 4

Toleranz der Stiftabstände $\pm 0,2\text{mm}$

Einzelheit
Z

Type

T60404-N4646-X400

T60404-N4646-X410

T60404-N4646-X412

T60404-N4646-X413

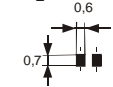
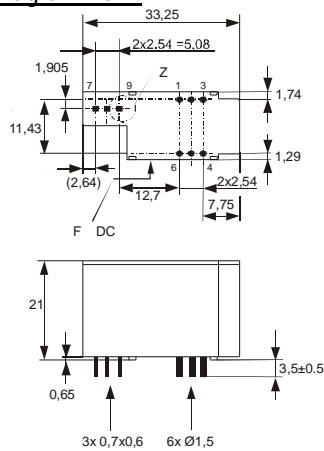

DC = Date Code
F = Factory

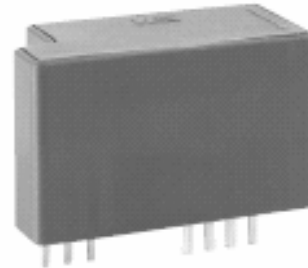

Diagram no. 5

Toleranz der Stiftabstände $\pm 0,2\text{mm}$

Einzelheit
Z

Type

T60404-N4644-X460

T60404-N4644-X461

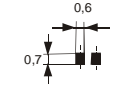
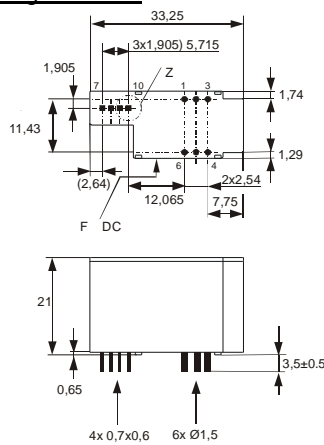

DC = Date Code
F = Factory

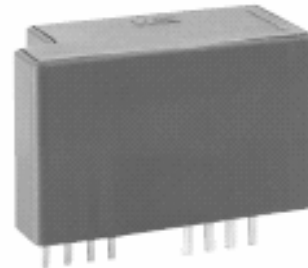







Cross-reference list

The sensors of the new VAC type series can replace competitive products in many cases and usually offer superior technical properties regarding accuracy, temperature drift and quality of the quiescent signal. The following table only lists the competitive types with which the new VAC types are electrically and mechanically compatible according to the data sheet comparison. The customer is responsible for the actual suitability in his specific application.

A large number of other competitive types can be replaced functionally but the user needs to make adaptations, e.g. change the circuit board layout. Please ask about these.

VAC item number Type T6040-N...	LEM	Honeywell	F.W. Bell	Tamura	Telcon	Remarks	
	4646-X653	LTS 6-NP ¹			S22P006S05	(1) VAC – type with smaller centre hole	
	4646-X652	LTS 15-NP ¹			S22P015S05	(1) VAC – type with smaller centre hole	
	4646-X651	LTS 25-NP ¹			S22P025S05	(1) VAC – type with smaller centre hole	
	4646-X663	LTSR 6-NP ¹				(1) VAC – type with smaller centre hole	
	4646-X662	LTSR 15-NP ¹				(1) VAC – type with smaller centre hole	
	4646-X661	LTSR 25-NP ¹				(1) VAC – type with smaller centre hole	
	4646-X300	LA 25-NP	CSNE 151 CSNE 151-005 CSNE 151-006 CSNE 151-007 CSNE 151-010	CLN 25 CLSM 25 ²		HTP25NP (2) F.W. Bell - type suitable for V _{DC} up to ± 18 V	
	4646-X400	LAH 25-NP				HTP25CPT ³ HTP25CPTH ^{3,4}	(3) VAC housing 3mm wider (4) Telcon – type with add. centre hole
	4646-X410	LAH 50-P/SP1				HTP50CPT ³ HTP50CPTH ^{3,4}	(3) VAC housing 3mm wider (4) Telcon – type with add. centre hole
	4646-X412	LAH 50-P				HTP50CPT/2K ^{3,4}	(3) VAC housing 3mm wider (4) Telcon – type with add. centre hole
	4646-X412	LAH 100-P				HTP100CPT/2K ³	(3) VAC housing 3mm wider
	4646-X413	LAH 100-P/SP3					
	4646-X460	LAS 50-TP LAS 50-TP/SP1					
	4646-X461	LAS 100-TP LAS 100-TP/SP1					



Technical appendix

Functional principle of VAC current sensors

Two major advantages of the compensation current sensors are their principle-related high linearity and their excellent dynamic properties. The current I_p to be measured is magnetically coupled to the compensation current through a soft magnetic core. The magnetic flux of this core is measured by a magnetic field detector and controlled to zero by the electronics, generating a compensation current I_s in the compensation winding. This current is proportional to the primary current I_p .

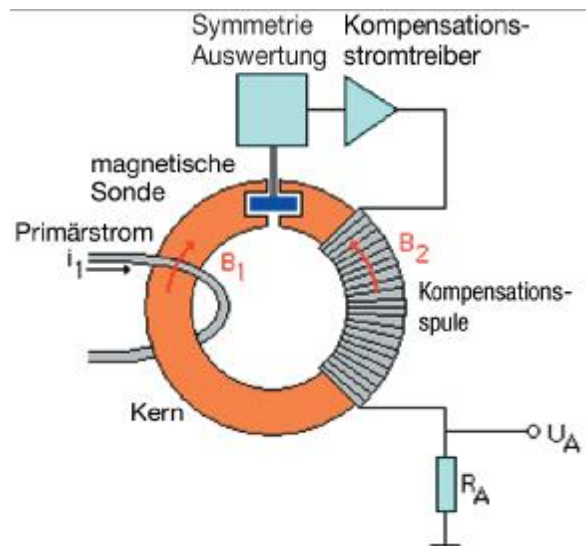

Different sensor principles - accuracy of the current capture and quality of the output signal

Open loop Hall effect - sensors without compensation coil. The accuracy of these types of sensors differs from the two other principles. Their error over the whole temperature range is 7.5 % to 12 %. About half of this error is temperature-dependent. The series scattering of the temperature responses of the Hall elements prevent the possibility of compensation. Their output signal also carries a lot of noise interference. Open loop Hall effect sensors can be used for less demanding applications.

Closed loop Hall effect – sensors. They achieve approximately half the accuracy of the VAC sensors, i.e. 2 % to 3 % over the permissible temperature range whereby this is smaller (typically -25 ... 85 °C instead of -40 ... 85 °C). Their output signal is superimposed by noise. This semiconductor noise is broadband and cannot be filtered out.

VAC closed loop sensors with magnetic probe. The sum of all errors (accuracy, linearity and offset) adds up to a value of about 1% to 1.5% over the whole (!) application temperature range of -40 ... 85 °C. This total value is more important than the error value only at room temperature. The quiescent signal of the VAC sensors only has a low level, is high frequency periodic and therefore easy to filter. There is practically no noise.

VAC compensation sensors offer high continuous and peak currents in a very compact form

The types T60404-N4646-X654, or X664 detect maximum rms continuous currents up to 50 A and peak currents up to ± 150 A in a design with the dimensions 22.2 mm x 10.0 mm x 24 mm (L x W x H).

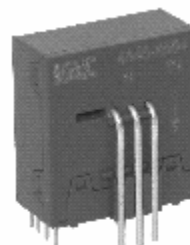



Reflow – solderable types available

The type series T60404-N4646-X67.. and X68.. are electrically and mechanically compatible to the series T60404-N4646-X6.. and X66... They are however reflow – solderable and are therefore suitable for the automated processing e.g. on PCBs, which are exclusive or predominantly equipped with SMD components.

The graph shows the temperature profile for lead free soldering as suggested by VAC. The optimal soldering profile for the specific application must be determined by the user.

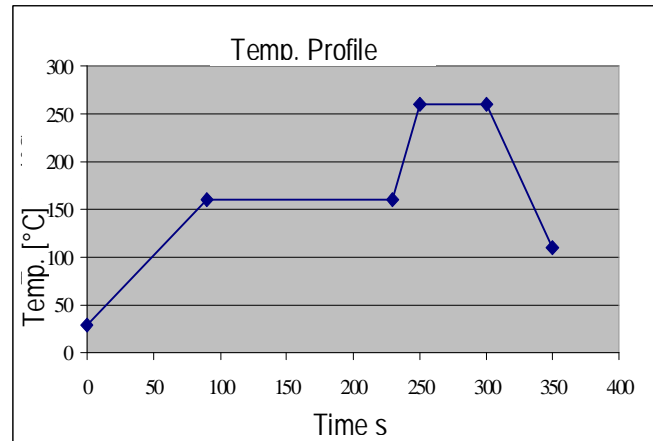

Diagrams

Measured at the VAC sensor with unipolar +5 V supply and voltage output. T60404-N4646-X661, $I_{P,N} = 25 \text{ A}$, $I_{P,max.} = \pm 85 \text{ A}$.

Temperature response offset

Fig. 2: Low offset, almost temperature-independent, easily compensatable ($I_P = I_{P,N}$)

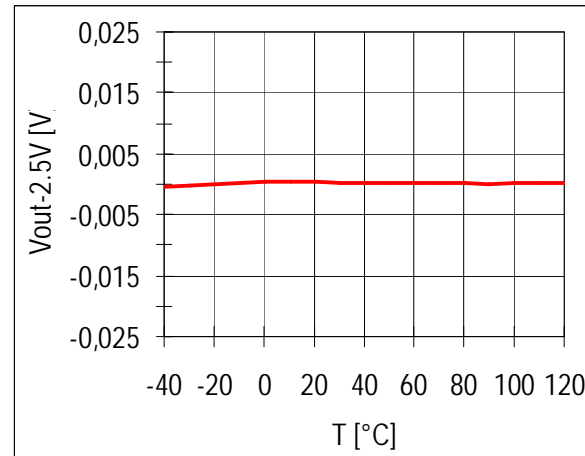



Temperature response gain

Fig. 3: Low gain error, almost temperature-independent ($I_P = I_{P,N}$)

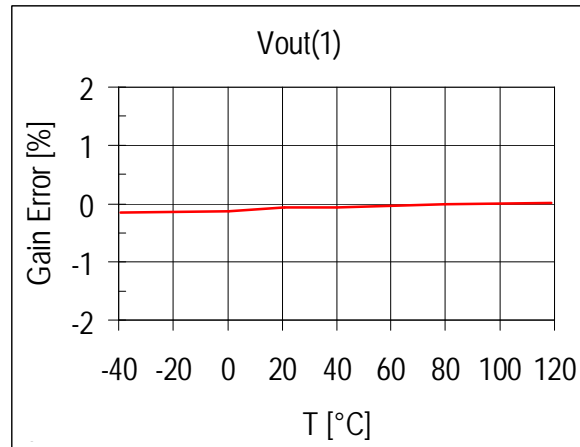

Pulse response

Fig. 4: The output signal V_{out} (here expressed as the equivalent of the input current) follows the input signal with negligible delay and adapts quickly to the static value. Shown here for $I_P = 25$ A and $I_P = 80$ A

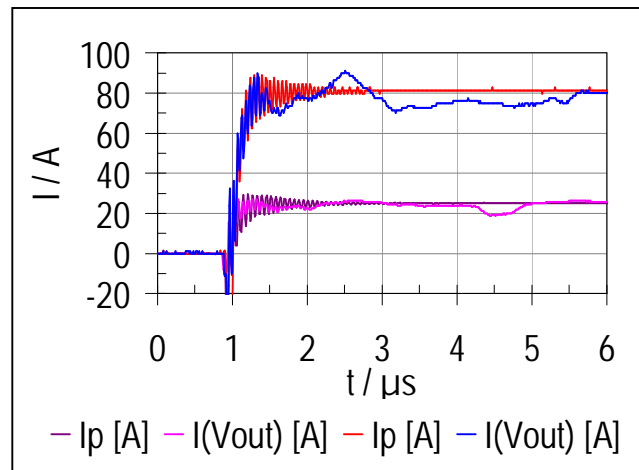



VACUUMSCHMELZE GmbH & Co. KG

Advanced Materials – The Key to Progress

P.O.B. 2253
D-63412 Hanau
☎ (**49) 6181 / 38-0
Fax (**49) 6181 / 38-2780
E-Mail: Info@vacuumschmelze.com
<http://www.vacuumschmelze.com>