

V4NC

Snap-action Microswitches

Subminiature

V4NC

- Characteristics
- Peg mounting option
 - Solder terminals
 - 2.8 mm faston (quick connect) terminals
 - PCB terminals
 - Sealed (IP 67) / unsealed (IP 40)
 - Pre-wired option
 - Snap-on terminal covers

Rating 250 VAC, 5 A

Dimensions (mm) V4NC 20 × 10,3 × 6,4
V4NCS 20 × 10,3 × 6,4

Actuator Plunger, plain levers, roller levers

Approvals None

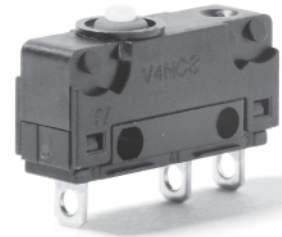

Preferred Range

Ordering Reference	Actuating Force (N)	Actuating Force (ozf)	Sealing	Operating pos. (mm)	Operating pos. (in)	Terminal	Circuit	Actuator	Contacts	Electrical rating
V4NCT7	1,7	6,114	No digit	8,40	0,331	Solder	CO	Plunger	Fine silver	250 VAC, 5 A
V4NCT7A1	0,8	2,877	No digit	10,85	0,427	Solder	CO	Plain lever	Fine silver	250 VAC, 5 A
V4NCT7AR1	0,8	2,877	No digit	16,00	0,630	Solder	CO	Roller lever	Fine silver	250 VAC, 5 A
V4NCSK2	2,5	8,992	Sealed IP 6K7	8,40	0,331	Cable 500 mm	CO	Plunger	Fine silver	250 VAC, 5 A
V4NCSK2A1	0,9	3,237	Sealed IP 6K7	10,80	0,425	Cable 500 mm	CO	Plain lever	Fine silver	250 VAC, 5 A
V4NCSK2AR1	0,9	3,237	Sealed IP 6K7	15,90	0,626	Cable 500 mm	CO	Roller lever	Fine silver	250 VAC, 5 A
V4NCSK2	2,5	8,992	Sealed IP 6K7	8,40	0,331	Cable 500 mm	CO	Plunger	Fine silver	250 VAC, 5 A
V4NCSK2A1	0,9	3,237	Sealed IP 6K7	10,80	0,425	Cable 500 mm	CO	Plain lever	Fine silver	250 VAC, 5 A
V4NCSK2AR1	0,9	3,237	Sealed IP 6K7	15,90	0,626	Cable 500 mm	CO	Roller lever	Fine silver	250 VAC, 5 A

Specifications

Housing	Glass fibre reinforced Polyamide (PA 6.6)
Plunger	Polyacetal POM/(PA 4.6)
Mechanism	Snap-action coil spring mechanism with stainless steel spring
Functions	Change-over, normally-closed or normally-open
Contacts	Fine Silver, Gold plate on silver, Gold alloy on silver palladium (crosspoint)
Terminals	Gold flashed
Temperature range °C	-40°C to +85°C/120°C
Mechanical life	5 × 10 ⁶ cycles minimum (impact free actuation)
Protection	IP 40, IP 6K7, Flux-proof terminal entries (depend on type)
Mounting	Side mounting (moulded mounting pegs on request)
Actuators	Plain lever, cam follower, roller lever, simulated roller (cam follower) lever
Accessories	Lug mounting frame, clip-on terminals cover, insulating sheet

Circuit diagram V4NCT7

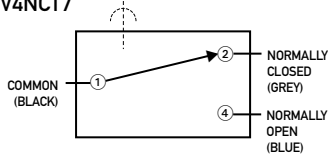

Dimensions

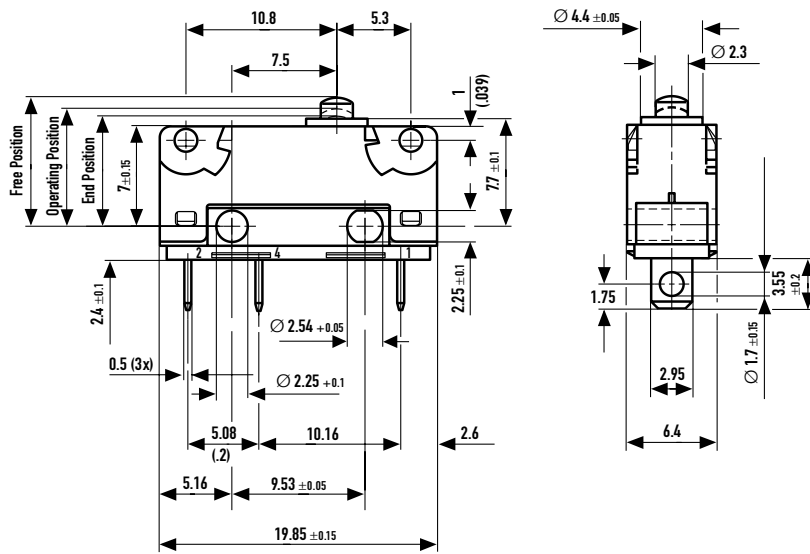

Operating Characteristics

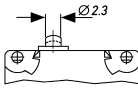
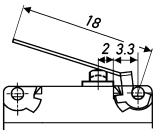
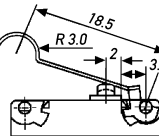
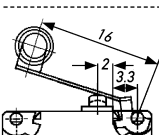
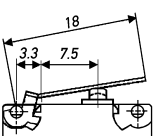
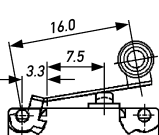
Actuator	Reference	Actuating Force Maximum		Release Force Minimum		Free Position Maximum		Operating Position		Movement Differential Maximum	
		(N)	(ozf)	(N)	(ozf)	(mm)	(in)	(mm)	(in)	(mm)	(in)
 <p>Width of lever 4.0mm/0.16 in</p>	V4NC..	1.7	6.114	0.3	1.079	9.2	0.362	8.4 ± 0.3	0.331 ± 0.012	0.1	0.004
	V4NC4..	2.5	8.992	0.5	1.798	9.2	0.362	8.4 ± 0.3	0.331 ± 0.012	0.1	0.004
	V4NCE..	1.7	6.114	0.3	1.079	9.7	0.382	8.9 ± 0.3	0.35 ± 0.012	0.1	0.004
	V4NC4E..	2.5	8.992	0.5	1.798	9.7	0.382	8.9 ± 0.3	0.35 ± 0.012	0.1	0.004
	V4NC4S..	2.8	10.071	0.7	2.517	9.2	0.362	8.4 ± 0.3	0.331 ± 0.012	0.1	0.004
	V4NC4SE..	2.5	8.992	0.5	1.798	9.7	0.382	8.9 ± 0.3	0.35 ± 0.012	0.1	0.004
	V4NC4SE..	2.8	10.071	0.7	2.517	9.7	0.382	8.9 ± 0.3	0.35 ± 0.012	0.1	0.004
 <p>Width of lever 4.0mm/0.16 in</p>	V4NC..	0.8	2.877	0.07	0.251	13.4	0.527	10.85 ± 1.3	0.427 ± 0.051	0.4	0.016
	V4NC4..	1.1	3.956	0.1	0.359	13.4	0.527	10.85 ± 1.3	0.427 ± 0.051	0.4	0.016
	V4NCE..	0.8	2.877	0.07	0.251	14.8	0.582	12.4 ± 1.3	0.488 ± 0.051	0.4	0.016
	V4NC4E..	1.1	3.956	0.1	0.359	14.8	0.582	12.4 ± 1.3	0.488 ± 0.051	0.4	0.016
	V4NC4S..	0.9	3.237	0.1	0.359	13.4	0.527	10.8 ± 1.3	0.425 ± 0.051	0.4	0.016
	V4NC4SE..	1.1	3.956	0.15	0.539	13.4	0.527	10.8 ± 1.3	0.425 ± 0.051	0.4	0.016
	V4NC4SE..	0.9	3.237	0.1	0.359	14.8	0.582	12.4 ± 1.3	0.488 ± 0.051	0.4	0.016
 <p>Width of lever 4.0mm/0.16 in</p>	V4NC..	0.8	2.877	0.07	0.251	16.1	0.634	13.5 ± 1.3	0.531 ± 0.051	0.4	0.016
	V4NC4..	1.1	3.956	0.1	0.359	16.1	0.634	13.5 ± 1.3	0.531 ± 0.051	0.4	0.016
	V4NCE..	0.8	2.877	0.07	0.251	17.6	0.693	15.1 ± 1.3	0.594 ± 0.051	0.4	0.016
	V4NC4E..	1.1	3.956	0.1	0.359	17.6	0.693	15.1 ± 1.3	0.594 ± 0.051	0.4	0.016
	V4NC4S..	0.9	3.237	0.1	0.359	16.1	0.634	13.4 ± 1.3	0.527 ± 0.051	0.4	0.016
	V4NC4SE..	1.1	3.956	0.15	0.539	16.1	0.634	13.4 ± 1.3	0.527 ± 0.051	0.4	0.016
	V4NC4SE..	0.9	3.237	0.1	0.359	17.6	0.693	15.1 ± 1.3	0.594 ± 0.051	0.4	0.016
 <p>Width of lever 4.0mm/0.16 in</p>	V4NC..	0.8	2.877	0.07	0.251	18.1	0.712	16 ± 1.2	0.63 ± 0.047	0.4	0.016
	V4NC4..	1.2	4.316	0.1	0.359	18.1	0.712	16 ± 1.2	0.63 ± 0.047	0.4	0.016
	V4NCE..	0.8	2.877	0.07	0.251	19.2	0.756	17.3 ± 1.2	0.681 ± 0.047	0.4	0.016
	V4NC4E..	1.2	4.316	0.1	0.359	19.2	0.756	17.3 ± 1.2	0.681 ± 0.047	0.4	0.016
	V4NC4S..	0.9	3.237	0.1	0.359	18.1	0.712	15.9 ± 1.2	0.626 ± 0.047	0.4	0.016
	V4NC4SE..	1.2	4.316	0.15	0.539	18.1	0.712	15.9 ± 1.2	0.626 ± 0.047	0.4	0.016
	V4NC4SE..	0.9	3.237	0.1	0.359	19.2	0.756	17.3 ± 1.2	0.681 ± 0.047	0.4	0.016
 <p>Width of lever 4.0mm/0.16 in</p>	V4NC..	1.3	4.676	0.13	0.467	10.7	0.421	9.4 ± 0.7	0.37 ± 0.027	0.2	0.008
	V4NC4..	1.7	6.114	0.2	0.719	10.7	0.421	9.4 ± 0.7	0.37 ± 0.027	0.2	0.008
	V4NCE..	1.3	4.676	0.13	0.467	11.5	0.453	10.2 ± 0.7	0.401 ± 0.027	0.2	0.008
	V4NC4E..	1.7	6.114	0.2	0.719	11.5	0.453	10.2 ± 0.7	0.401 ± 0.027	0.2	0.008
	V4NC4S..	1.8	6.474	0.2	0.719	10.7	0.421	9.3 ± 0.7	0.366 ± 0.027	0.2	0.008
	V4NC4SE..	2	7.193	0.3	1.079	10.7	0.421	9.3 ± 0.7	0.366 ± 0.027	0.2	0.008
	V4NC4SE..	1.8	6.474	0.2	0.719	11.5	0.453	10.1 ± 0.7	0.397 ± 0.027	0.2	0.008
 <p>Width of lever 4.0mm/0.16 in</p>	V4NC..	1.3	4.676	0.13	0.467	15.8	0.622	14.7 ± 0.6	0.579 ± 0.023	0.2	0.008
	V4NC4..	1.9	6.834	0.2	0.719	15.8	0.622	14.7 ± 0.6	0.579 ± 0.023	0.2	0.008
	V4NCE..	1.3	4.676	0.13	0.467	16.5	0.649	15.4 ± 0.6	0.606 ± 0.023	0.2	0.008
	V4NC4E..	1.9	6.834	0.2	0.719	16.5	0.649	15.4 ± 0.6	0.606 ± 0.023	0.2	0.008
	V4NC4S..	1.8	6.474	0.2	0.719	15.8	0.622	14.7 ± 0.6	0.579 ± 0.023	0.2	0.008
	V4NC4SE..	2.1	7.553	0.3	1.079	15.8	0.622	14.7 ± 0.6	0.579 ± 0.023	0.2	0.008
	V4NC4SE..	1.8	6.474	0.2	0.719	16.5	0.649	15.4 ± 0.6	0.606 ± 0.023	0.2	0.008

Operating characteristics shown above are specified from mounting hole centres.

Over travel: Flush with case. (7.8 mm min) The case should not be used as an end stop.

Ordering Reference

Type	V4NC					
Actuating Characteristic	No digit	Standard force				
	4	High force				
Type of sealing	No digit	Unsealed				
	S	Sealed IP 6K7				
Overtravel	No digit	Standard				
	E	With extended over travel				
Terminals	T6	Faston	2.03 × 0.8	T81	Bent PCB	0.8 × 0.5
	T7	Solder	2.95 × 0.5	T82	Bent PCB	0.8 × 0.5
	T8	PCB	0.8 × 0.8	T83	Bent PCB	0.8 × 0.5
	T9	Faston	2.8 × 0.5	T84	Bent PCB	0.8 × 0.5
	T11	Faston	2.95 × 0.5	T85	PCB	0.8 × 0.5
				T86	PCB	0.8 × 0.5
Cover	K1	5.5 mm max.				
	K2	8.7 mm max.				
	K3	10.7 mm max.				
Circuit	No digit	Change-over				
	C2	Normally closed				
	C4	Normally open				
Actuators	No digit	Plunger				
	A1	Plain lever	18.0 mm / 0.71 in			
	A2	Plain lever	25.0 mm / 0.98 in			
	A3	Plain lever	32.0 mm / 1.26 in			
	A7	Plain lever	60.0 mm / 2.36 in			
	AC1	Cam follower	18.5 mm / 0.73 in			
	AR1	Roller lever	16.0 mm / 0.63 in			
	Levers fitted at end nearest to plunger.					
	An attached "0" such as A10, AR10 specifies fixing at end of the opposite to plunger					
Mounting	No digit	Mounting holes				
	B...	Several mounting pegs on request				
Contacts	No digit	Fine silver				
	Ni1	Silver-Nickel				
	GP	Gold plate on silver				
	AUX	Gold alloy on silver palladium crosspoint				