

Important Note:

These instructions are for use of trained electricians only, describing how to mount 3 pole field assembly waterproof connector. You can find technical information at www.ttaf.com.tr or you can call us from 00 902128558220 (10 line).

1) Parts of the connector

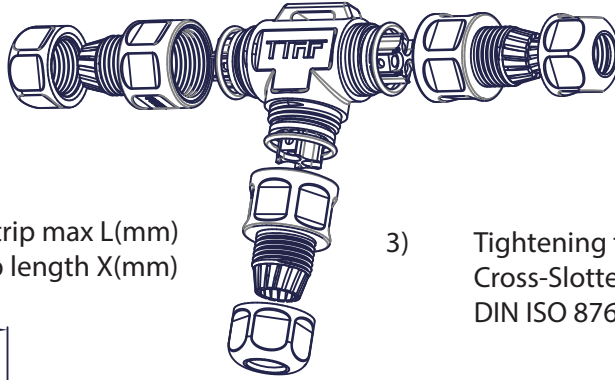

2) Outer sheath strip max L(mm)
Insulation strip length X(mm)

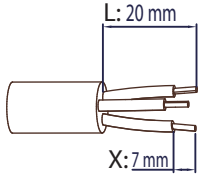

3) Tightening torque 0,5Nm
Cross-Slotted head screwdriver
DIN ISO 8764

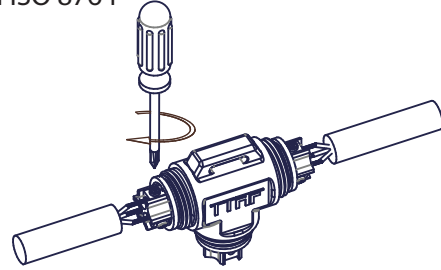

4) Push and turn connector parts

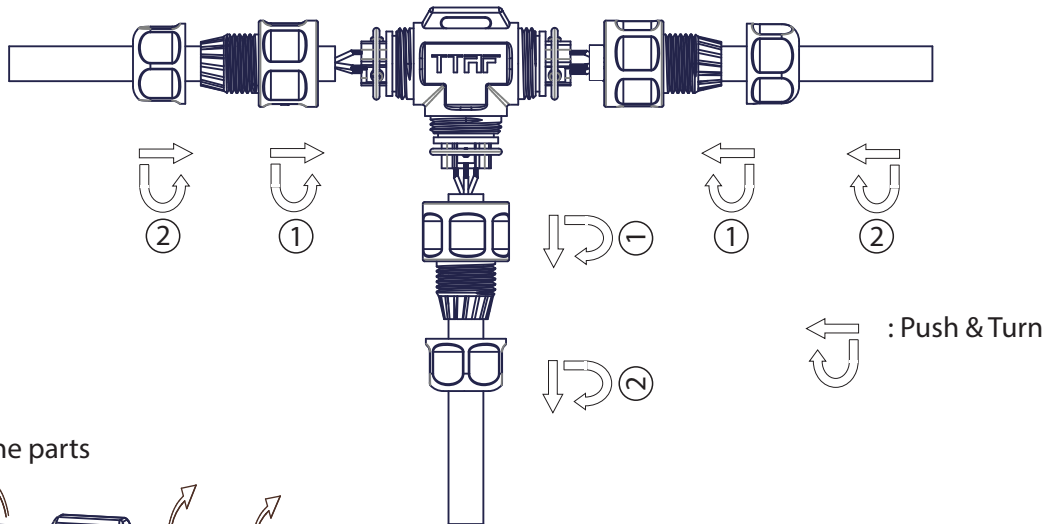

5) Lock the parts

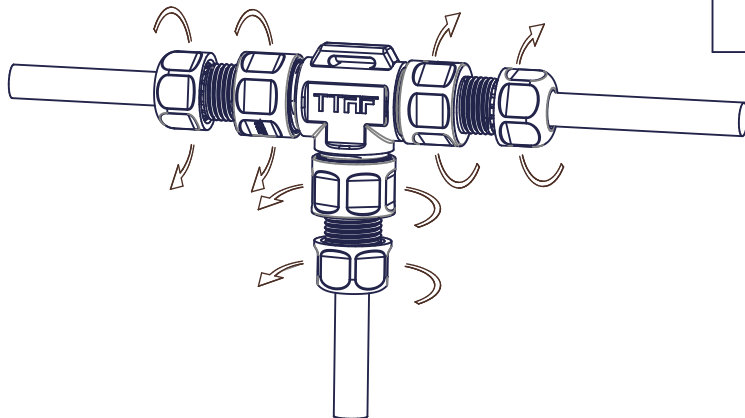

6) Tightening torque 2-2,5Nm

