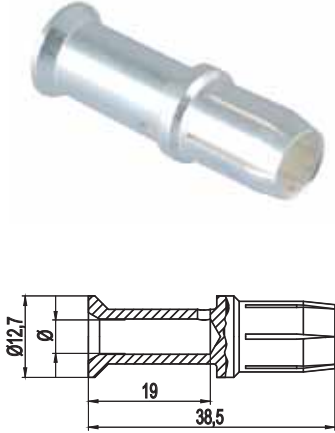
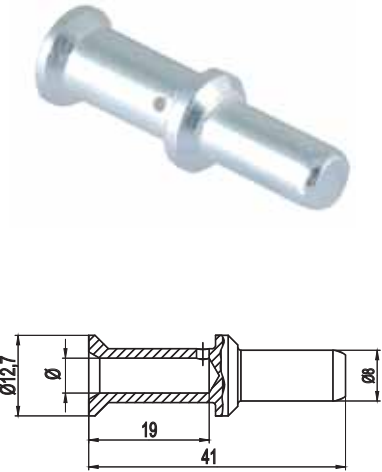

Female turned crimp contacts Contatti femmina a crimpare torniti	Ø mm	Stripping length Spellatura filo	Wire mm ² Filo mm ²	Wire gauge Calibro filo	Part No. Codice
 <p> - Material: Copper alloy Materiale: Lega di rame - Surface: Silver plated Finitura: Argentati </p>	4,3	19	10	7 AWG	7700.3131.0
	5,5	19	16	5 AWG	7700.3132.0
	7	19	25	4 AWG	7700.3133.0
	8,2	16	35	2 AWG	7700.3134.0
<p>Male turned crimp contacts Contatti maschio a crimpare torniti</p>	Ø mm	Stripping length Spellatura filo	Wire mm ² Filo mm ²	Wire gauge Calibro filo	Part No. Codice
	 <p> - Material: Copper alloy Materiale: Lega di rame - Surface: Silver plated Finitura: Argentati </p>	4,3	19	10	7 AWG
5,5		19	16	5 AWG	7700.3136.0
	7	19	25	4 AWG	7700.3137.0
	8,2	16	35	2 AWG	7700.3138.0
<p>For inserts series: <i>Per inserti serie:</i> S-K, S-M</p>	<p>Dimensions in mm Part No. bold letters refer to standard availability. Normal letters refer to items on special request. Dimensioni in mm I codici in grassetto indicano i prodotti di normale disponibilità. Il carattere normale indica i prodotti speciali su richiesta.</p>				<p>Crimping tools: see section 60 Attrezzi per crimpare: vedere sezione 60</p>