

- NOTES:
- MATERIAL:
 - A) ADAPTER PLATE: COLD ROLLED STEEL (CRS)
 - B) CAPTIVE SCREW : ZINC PLATED HARDENED CARBON STEEL.
 - C) PHILLIPS PAN HEAD SCREW: GALVANIZED STEEL
 - FINISH:
 - ADAPTER PLATE : GOTHIC BLACK TEXTURE (RAL 000 15 00) POWDER COAT.
 - ASSEMBLY IS PACKED INDIVIDUALLY IN A BOX.

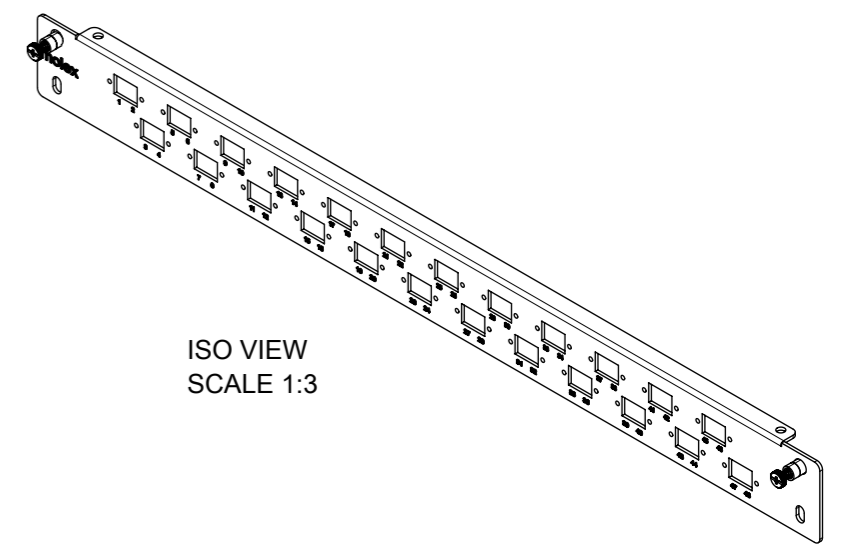
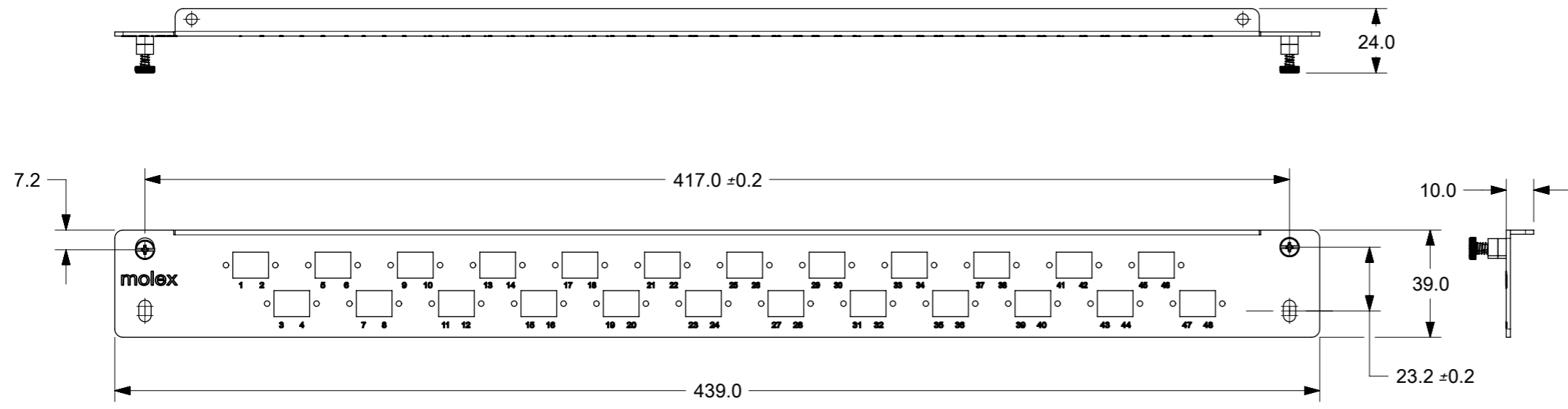

PART NUMBER CHART		
MPN NO.	SAP NO.	DESCRIPTION
AFR-00477-04	180600376	ADAPT PLATE MFE 48F DLC UNLD BLACK

SYMBOLS DIMENSION UNITS SCALE GENERAL TOLERANCES (UNLESS SPECIFIED) MM INCH ANGULAR TOL ± 0.5° DRAFT WHERE APPLICABLE MUST REMAIN WITHIN DIMENSIONS THIRD ANGLE PROJECTION DRAWING SERIES MATERIAL NUMBER CUSTOMER SHEET NUMBER	THIS DRAWING CONTAINS INFORMATION THAT IS PROPRIETARY TO MOLEX ELECTRONIC TECHNOLOGIES, LLC AND SHOULD NOT BE USED WITHOUT WRITTEN PERMISSION		CURRENT REV DESC: EC NO: 615758 DRWN: UKOWSHIKARAN 2019/04/11 CHK'D: RCG 2019/05/07 APPR: RCG 2019/05/07		molex ADAPTER PLATE MFE 48F DLC UNLD-BLACK			
	4 PLACES ± ± 3 PLACES ± ± 2 PLACES ± ± 1 PLACE ± 0.5 ± 0 PLACES ± ±		INITIAL REVISION: DRWN: MTAMBRALLI 2012/12/06 APPR: RCG 2013/07/11				PRODUCT CUSTOMER DRAWING	
	DOCUMENT NUMBER SD-18060-067		DOC TYPE PSD		DOC PART 001		REVISION C	
	SEE TABLE		GENERAL MARKET		1 OF 1			

DOCUMENT STATUS	P1	RELEASE DATE	2019/05/07	15:50:09
-----------------	----	--------------	------------	----------