

NOTES:

- 1. MATERIAL:
 - A) ADAPTER PLATE: COLD ROLLED STEEL (CRS)
 - B) CAPTIVE SCREW : ZINC PLATED HARDENED CARBON STEEL.
 - C) PHILLIPS PAN HEAD SCREW: GALVANIZED STEEL.
- 2. FINISH:
 - ADAPTER PLATE : GOTHIC BLACK TEXTURE (RAL 000 15 00)
 - POWDER COAT.
- 3. ASSEMBLY IS PACKED INDIVIDUALLY IN A BOX.

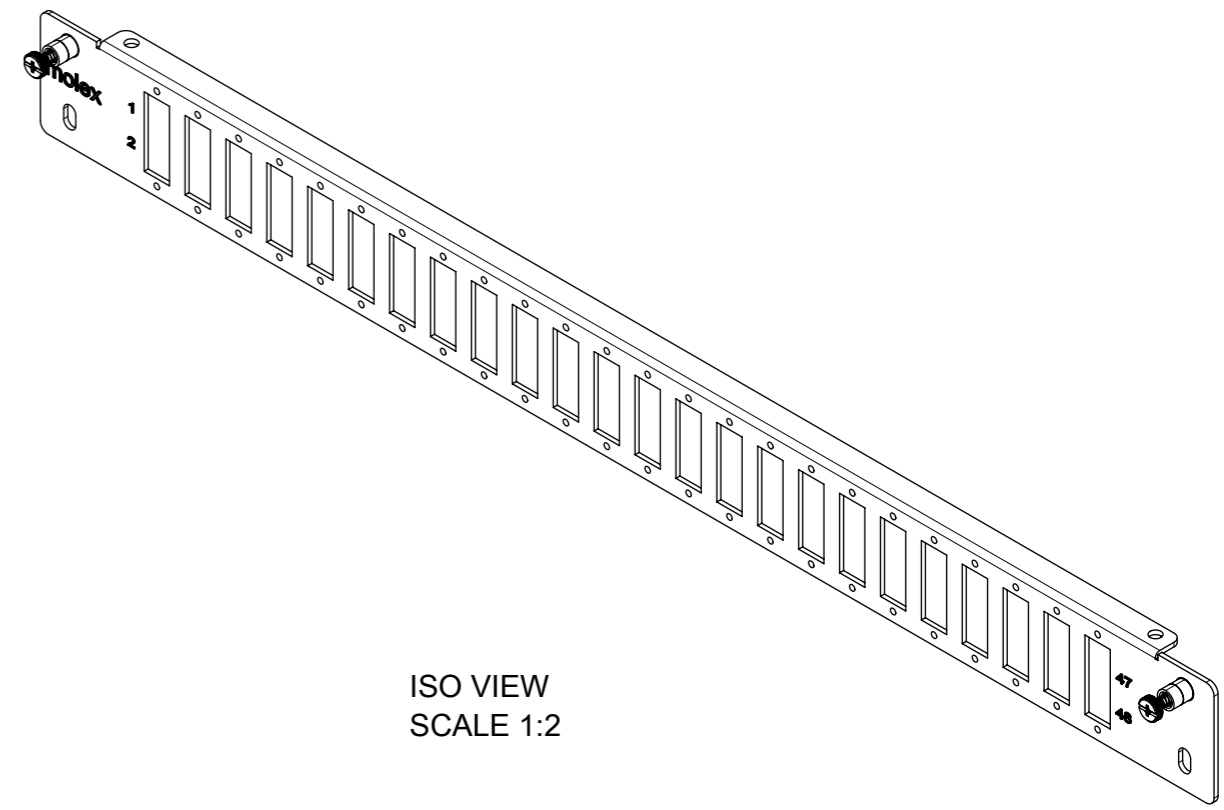
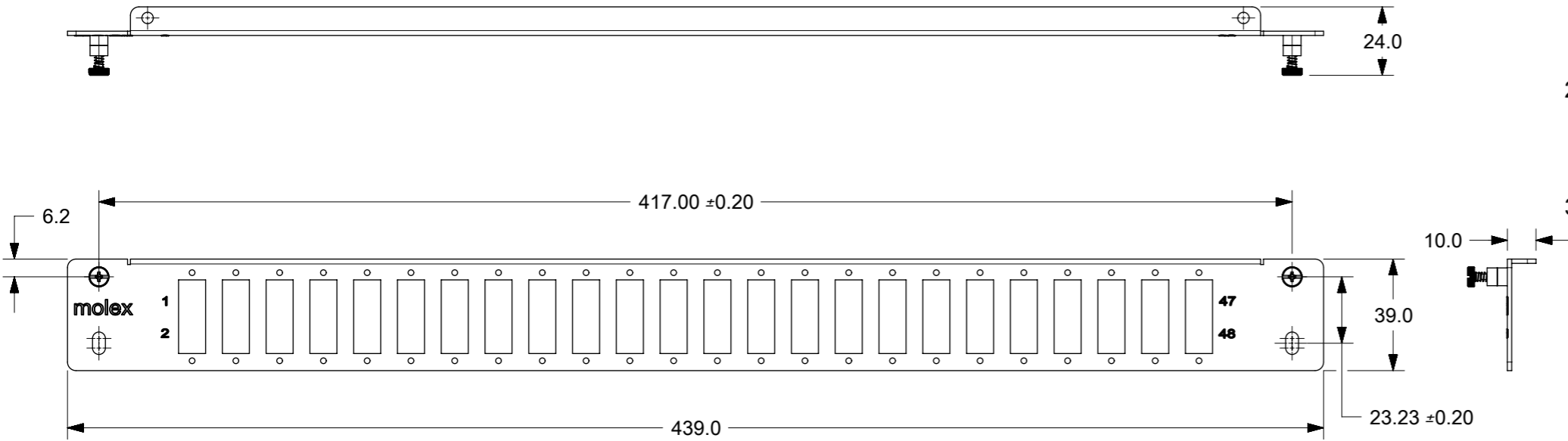

ISO VIEW
SCALE 1:2

MPN NO.	SAP NO.	DESCRIPTION
AFR-00478-04	180600377	ADAPT PLATE MFE 48F DSC UNLOADED BLACK

SYMBOLS ▽ = 0 ▽ = 0 ▽ = 0 ▽ = 0 ▽ = 0 ▽ = 0 ▽ = 0 ▽ = 0 ▽ = 0 ▽ = 0 ▽ = 0 ▽ = 0 ▽ = 0 ▽ = 0	THIS DRAWING CONTAINS INFORMATION THAT IS PROPRIETARY TO MOLEX ELECTRONIC TECHNOLOGIES, LLC AND SHOULD NOT BE USED WITHOUT WRITTEN PERMISSION DIMENSION UNITS: mm SCALE: 1:2	CURRENT REV DESC: EC NO: 615758 DRWN: UKOWSHIKARAN 2019/04/11 CHK'D: RCG 2019/05/07 APPR: RCG 2019/05/07			
	GENERAL TOLERANCES (UNLESS SPECIFIED) ANGULAR TOL ± 0.5°	INITIAL REVISION: DRWN: MTAMBRALLI 2012/12/06 APPR: RCG 2013/07/11	ADAPTER PLATE MFE 48F DSC UNLD-BLACK		
	4 PLACES ± 3 PLACES ± 2 PLACES ± 1 PLACE ± 0.5 0 PLACES ±	PRODUCT CUSTOMER DRAWING	DOCUMENT NUMBER: SD-18060-068	DOC TYPE: PSD	DOC PART: 001
	DRAFT WHERE APPLICABLE MUST REMAIN WITHIN DIMENSIONS	THIRD ANGLE PROJECTION	DRAWING: A3-SIZE	SERIES: 18060	MATERIAL NUMBER: SEE TABLE CUSTOMER: GENERAL MARKET
			SHEET NUMBER: 1 OF 1		