

NOTES:

1. MATERIAL:
 - A) ADAPTER PLATE: COLD ROLLED STEEL (CRS)
 - B) CAPTIVE SCREW : ZINC PLATED HARDENED CARBON STEEL.
 - C) PHILLIPS PAN HEAD SCREW: GALVANIZED STEEL
2. FINISH:
 - ADAPTER PLATE : GOTHIC BLACK TEXTURE (RAL 000 15 00) POWDER COAT.
3. ASSEMBLY IS PACKED INDIVIDUALLY IN A BOX.

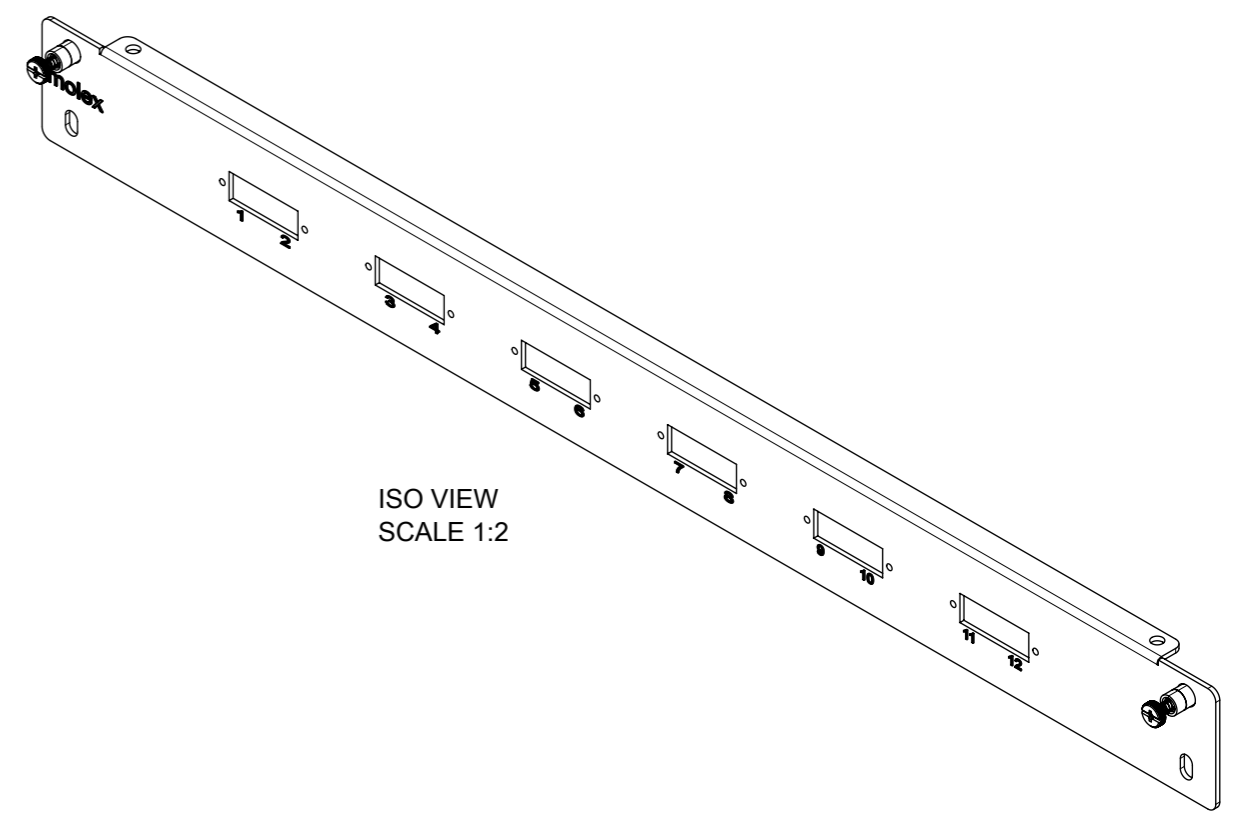

ISO VIEW
SCALE 1:2

PART NUMBER CHART		
MPN NO.	SAP NO.	DESCRIPTION
AFR-00518-04	180600396	ADAPT PLATE MFE 12F DSC UNLD BLACK

THIS DRAWING CONTAINS INFORMATION THAT IS PROPRIETARY TO MOLEX ELECTRONIC TECHNOLOGIES, LLC AND SHOULD NOT BE USED WITHOUT WRITTEN PERMISSION									
DIMENSION UNITS	SCALE	CURRENT REV DESC:					molex		
mm	1:2								
GENERAL TOLERANCES (UNLESS SPECIFIED)		EC NO: 615758					ADAPTER PLATE MFE 12F DSC UNLD - BLACK		
ANGULAR TOL	± 0.5 °	DRWN: UKOWSHIKARAN 2019/04/11							
4 PLACES	±	CHK'D: RCG 2019/05/07					PRODUCT CUSTOMER DRAWING		
3 PLACES	±	APPR: RCG 2019/05/07							
2 PLACES	±	INITIAL REVISION:					DOCUMENT NUMBER		
1 PLACE	± 0.5	DRWN: MTAMBRALLI 2013/12/25					SD-18060-086		
0 PLACES	±	APPR: RCG 2014/03/18					DOC TYPE	DOC PART	REVISION
DRAFT WHERE APPLICABLE MUST REMAIN WITHIN DIMENSIONS		THIRD ANGLE PROJECTION	DRAWING	SERIES	MATERIAL NUMBER	CUSTOMER		SHEET NUMBER	
		A3-SIZE	18060	SEE CHART	GENERAL MARKET		1 OF 1		

DOCUMENT STATUS	P1	RELEASE DATE	2019/05/07	15:50:24
-----------------	----	--------------	------------	----------