

NOTES:

1. MATERIAL:
  - A) ADAPTER PLATE: COLD ROLLED STEEL (CRS)
  - B) CAPTIVE SCREW : ZINC PLATED HARDENED CARBON STEEL.
  - C) PHILLIPS PAN HEAD SCREW: GALVANIZED STEEL
2. FINISH:
  - ADAPTER PLATE : GOTHIC BLACK TEXTURE (RAL 000 15 00)
  - POWDER COAT.
3. ASSEMBLY IS PACKED INDIVIDUALLY IN A BOX.

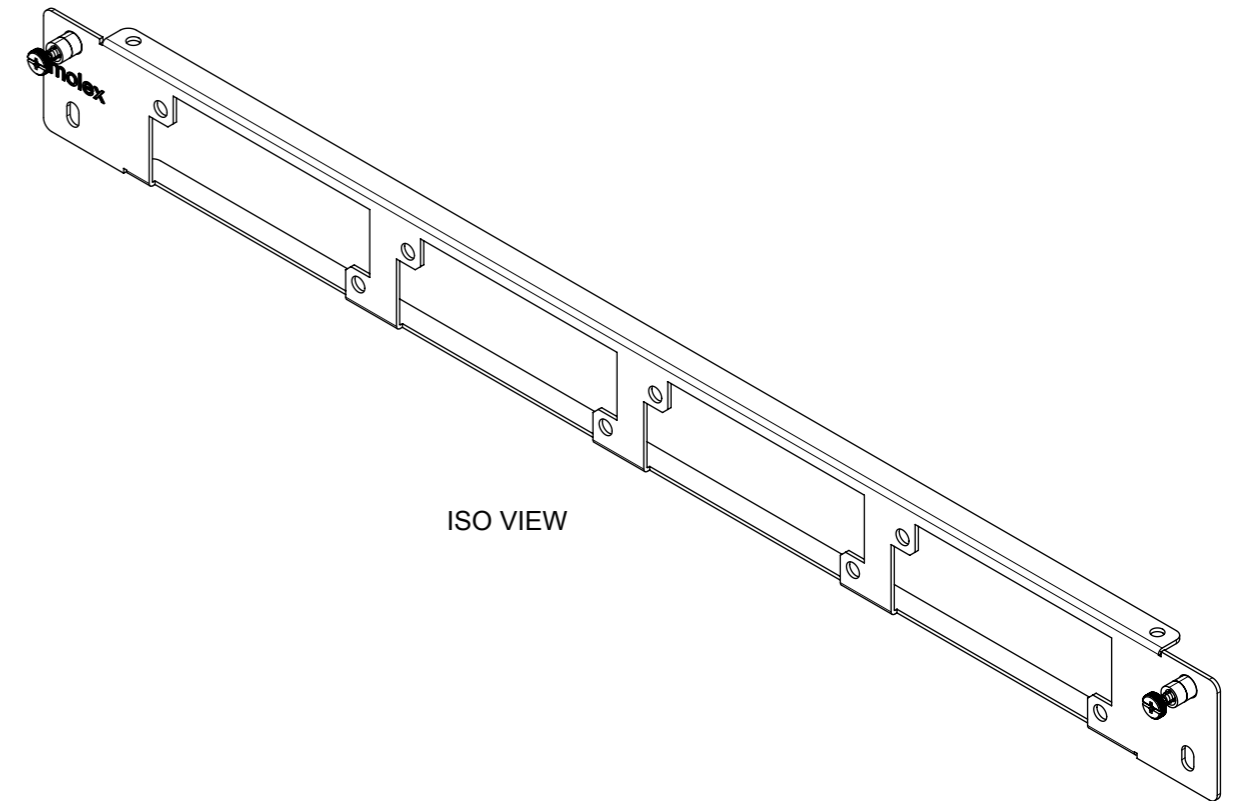

ISO VIEW

PART NUMBER CHART		
MPN NO.	SAP NO.	DESCRIPTION
AFR-00468-04	180600394	ADAPT PLATE MFE MULTIMEDIA BLACK UNLD

THIS DRAWING CONTAINS INFORMATION THAT IS PROPRIETARY TO MOLEX ELECTRONIC TECHNOLOGIES, LLC AND SHOULD NOT BE USED WITHOUT WRITTEN PERMISSION										
DIMENSION UNITS	SCALE	CURRENT REV DESC:					<b>molex</b>			
mm	1:2									
GENERAL TOLERANCES (UNLESS SPECIFIED)		EC NO: 615758					ADAPTER PLATE MFE MULTIMEDIA UNLD-BLACK			
ANGULAR TOL	±	DRWN: UKOWSHIKARAN 2019/04/11					PRODUCT CUSTOMER DRAWING			
4 PLACES	±	CHK'D: RCG 2019/05/07					DOCUMENT NUMBER			
3 PLACES	±	APPR: RCG 2019/05/07					SD-18060-058			
2 PLACES	±	INITIAL REVISION:					DOC TYPE			
1 PLACE	± 0.5	DRWN: MTAMBRALLI 2012/09/28					PSD			
0 PLACES	±	APPR: RCG 2013/07/11					DOC PART			
DRAFT WHERE APPLICABLE MUST REMAIN WITHIN DIMENSIONS		THIRD ANGLE PROJECTION	DRAWING	SERIES	MATERIAL NUMBER	CUSTOMER	REVISION			
			A3-SIZE	18060	SEE CHART	GENERAL MARKET	001 C			
							SHEET NUMBER			
							1 OF 1			