

9 8 7 6 5 4 3 2 1

NOTES:

1. MATERIAL:
 - A) ADAPTER PLATE: COLD ROLLED STEEL (CRS)
 - B) CAPTIVE SCREW : ZINC PLATED HARDENED CARBON STEEL.
 - C) PHILLIPS PAN HEAD SCREW: GALVANIZED STEEL
2. FINISH:
 - ADAPTER PLATE : GOTHIC BLACK TEXTURE (RAL 000 15 00)
 - POWDER COAT.
3. ASSEMBLY IS PACKED INDIVIDUALLY IN A BOX.

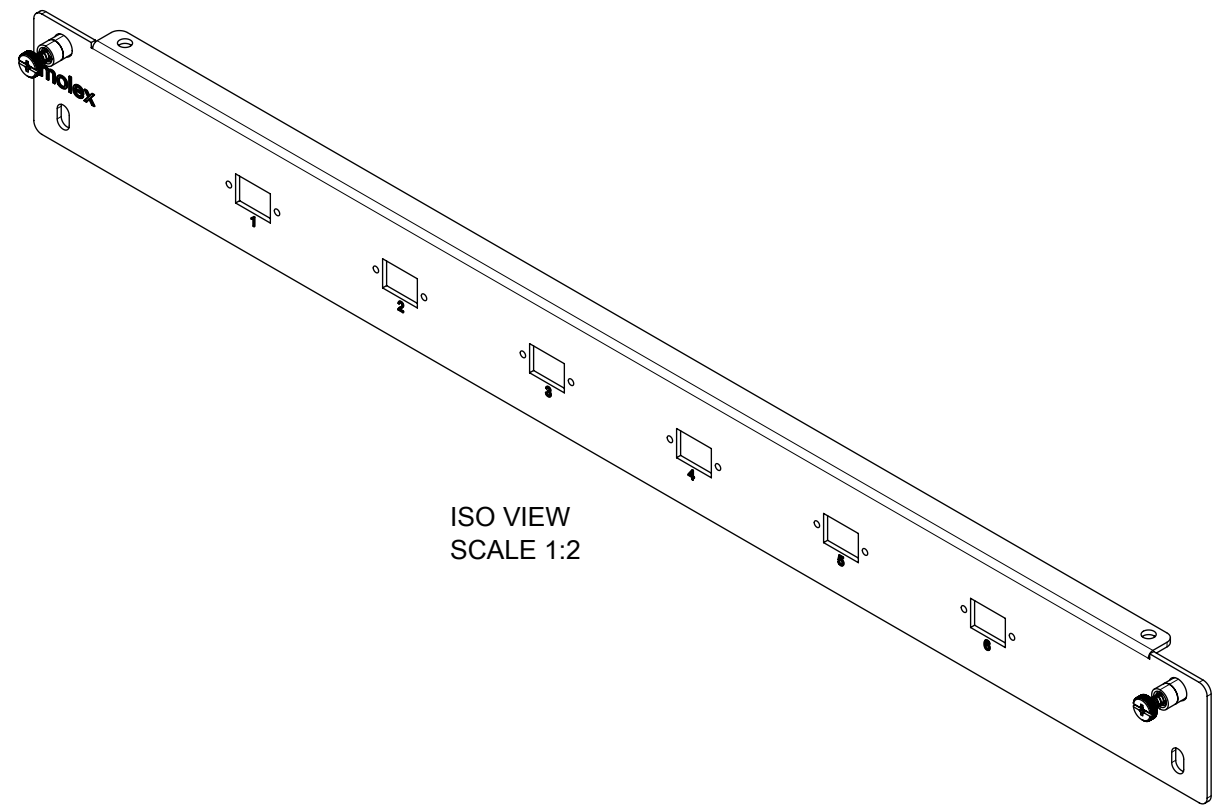
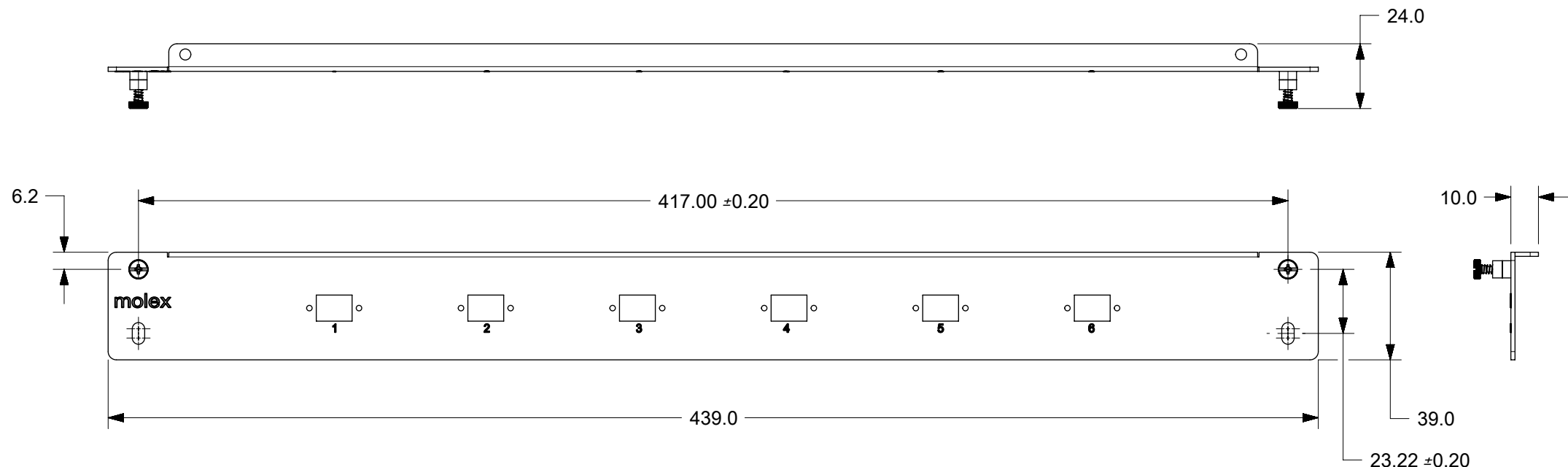

PART NUMBER CHART		
MPN NO.	SAP NO.	DESCRIPTION
AFR-00537-04	180600398	ADAPT PLATE MFE 6F SC SPX UNLD BLACK

THIS DRAWING CONTAINS INFORMATION THAT IS PROPRIETARY TO MOLEX ELECTRONIC TECHNOLOGIES, LLC AND SHOULD NOT BE USED WITHOUT WRITTEN PERMISSION											
DIMENSION UNITS mm		SCALE 1:2		CURRENT REV DESC:				molex		ADAPTER PLATE MFE 6F SC SPX UNLD - BLACK	
GENERAL TOLERANCES (UNLESS SPECIFIED)		ANGULAR TOL ± 0.5°		EC NO: 615758							
4 PLACES ±		3 PLACES ±		DRWN: UKOWSHIKARAN		2019/04/11		PRODUCT CUSTOMER DRAWING		DOCUMENT NUMBER SD-18060-094	
2 PLACES ±		1 PLACE ± 0.5		CHK'D: RCG		2019/05/07					
0 PLACES ±		DRAFT WHERE APPLICABLE MUST REMAIN WITHIN DIMENSIONS		APPR: RCG		2019/05/07		INITIAL REVISION:		DOC TYPE PSD	
THIRD ANGLE PROJECTION		DRAWING		SERIES		MATERIAL NUMBER		CUSTOMER		DOC PART 001	
A3-SIZE		18060		SEE CHART		GENERAL MARKET		SHEET NUMBER 1 OF 1		REVISION B	

DOCUMENT STATUS	P1	RELEASE DATE	2019/05/07	15:50:34
-----------------	----	--------------	------------	----------

9 8 7 6 5 4 3 2 1