

- NOTES:
- MATERIAL:
 - A) ADAPTER PLATE: COLD ROLLED STEEL (CRS)
 - B) ADAPTER HOUSING: POLYCARBONATE (PC)
 - C) CAPTIVE SCREW :ZINC PLATED HARDENED CARBON STEEL
 - D) PHILLIPS PAN HEAD SCREW: GALVANIZED STEEL
 - E) DUST CAP: LDPE
 - FINISH:
 - ADAPTER PLATE : GOTHIC BLACK TEXTURE POWDER COAT.
 - ACCOMODATES 24 LC DPLX ADAPTERS PER PLATE.
 - ASSEMBLY IS PACKED INDIVIDUALLY IN A BOX.
 - DUST CAPS ARE NOT SHOWN BUT, ASSEMBLED TO ADAPTERS.

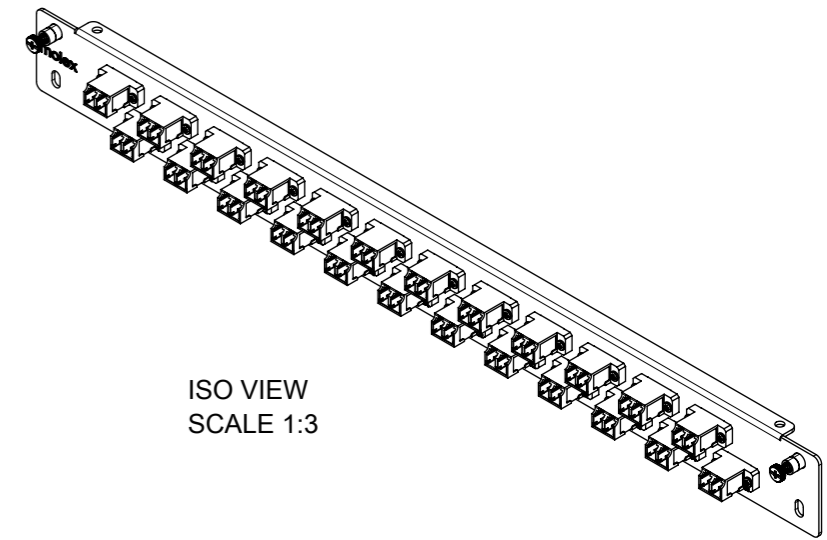

PART NUMBER CHART

MPN NO.	SAP NO.	DESCRIPTION
AFR-00603-BL	180600405	ADAPT PLATE MFE 48F SM OS1/2 DLC BLU
AFR-00604-GR	180600406	ADAPT PLATE MFE 48F SM OS1/2 DLC GRN APC
AFR-00605-OL	180600407	ADAPT PLATE MFE 48F MM OM1/OM2 DLC BG
AFR-00606-AQ	180600408	ADAPT PLATE MFE 48F MM OM3/OM4 DLC AQ
AFR-00607-EV	180600409	ADPTR PLATE MFE 48F MM OM4 DLC EV
AFR-00689-LG	180600459	ADPTR PLATE MFE 48F MM OM5 DLC LIMEGRN

SYMBOLS DIMENSION UNITS: mm SCALE: 1:2 GENERAL TOLERANCES (UNLESS SPECIFIED): ANGULAR TOL: ± ° 4 PLACES: ± 3 PLACES: ± 2 PLACES: ± 1 PLACE: ± 0.5 0 PLACES: ± DRAFT WHERE APPLICABLE MUST REMAIN WITHIN DIMENSIONS THIRD ANGLE PROJECTION	THIS DRAWING CONTAINS INFORMATION THAT IS PROPRIETARY TO MOLEX ELECTRONIC TECHNOLOGIES, LLC AND SHOULD NOT BE USED WITHOUT WRITTEN PERMISSION		CURRENT REV DESC: EC NO: 615758 DRWN: UKOWSHIKARAN 2019/04/11 CHK'D: RCG 2019/05/07 APPR: RCG 2019/05/07			
	ADAPTER PLATE MFE 48F DLC - BLACK		PRODUCT CUSTOMER DRAWING			
	INITIAL REVISION: DRWN: MTAMBRALLI 2012/09/27 APPR: RCG 2013/07/11		DOCUMENT NUMBER: SD-18060-051	DOC TYPE: PSD	DOC PART: 001	REVISION: C
	MATERIAL NUMBER: SEE CHART		CUSTOMER: GENERAL MARKET		SHEET NUMBER: 1 OF 1	