

NOTES:

- MATERIAL:
 - A) ADAPTER PLATE: COLD ROLLED STEEL (CRS)
 - B) ADAPTER HOUSING: POLYBUTYLENE TEREPHTHALATE + FIBERGLASS
 - C) CAPTIVE SCREW: ZINC PLATED HARDENED CARBONSTEEL
 - D) PHILLIPS PAN HEAD SCREW: GALVANIZED STEEL
 - E) DUST CAP: PP
- FINISH:
 - ADAPTER PLATE :GOTHIC BLACK TEXTURE POWDER COAT.
- ACCOMODATES 24 SC DPLX ADAPTERS PER PLATE.
- ASSEMBLY IS PACKED INDIVIDUALLY IN A BOX.
- DUST CAPS ARE NOT SHOWN BUT, ASSEMBLED TO ADAPTERS.

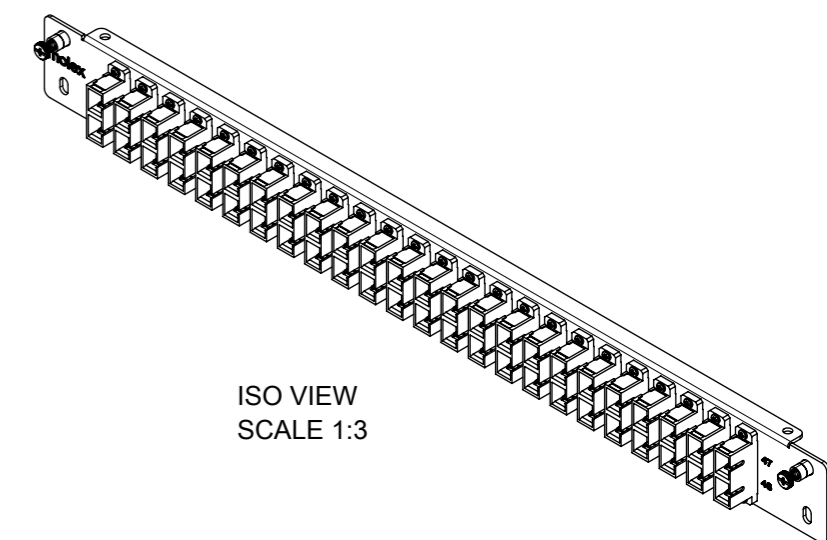
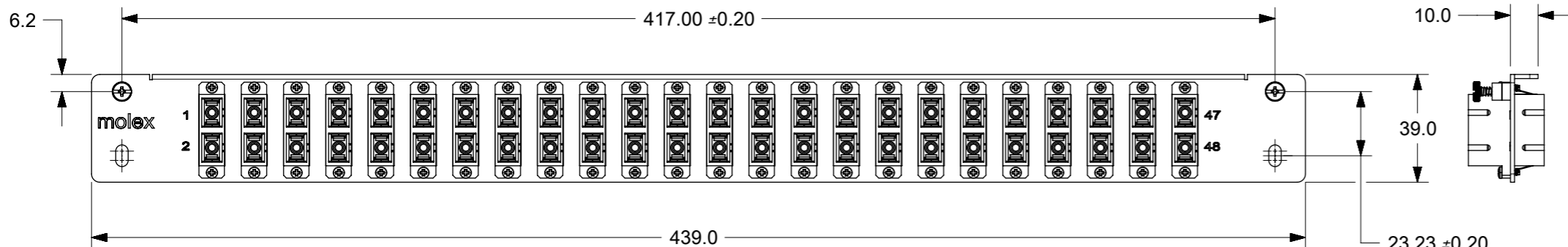

ISO VIEW
SCALE 1:3

PART NUMBER CHART

| MPN NO. | SAP NO. | DESCRIPTION |
|--------------|-----------|------------------------------------------|
| AFR-00608-BL | 180600410 | ADAPT PLATE MFE 48F SM OS1/2 DSC BLU |
| AFR-00609-GR | 180600411 | ADAPT PLATE MFE 48F SM OS1/2 DSC GRN APC |
| AFR-00610-OL | 180600412 | ADAPT PLATE MFE 48F MM OM1/OM2 DSC BG |
| AFR-00611-AQ | 180600413 | ADAPT PLATE MFE 48F MM OM3/OM4 DSC AQ |
| AFR-00612-EV | 180600414 | ADAPT PLATE MFE 48F MM OM4 DSC EV |
| AFR-00690-LG | 180600460 | ADAPT PLATE MFE 48F MM OM5 DSC LIMEGRN |

| | | | | | | |
|-----------------------------------------------------------------------------------------------------------------------------------------------------------------------------------------------------------------------------------------------------------------------------------|-----------------------------------------------------------------------------------------------------------------------------------------------|--|----------------------------------------------------------------------------------------------------------------------|---------------|---------------|-------------|
| SYMBOLS DIMENSION UNITS: mm SCALE: 1:2 GENERAL TOLERANCES (UNLESS SPECIFIED): ANGULAR TOL: ± ° 4 PLACES: ± 3 PLACES: ± 2 PLACES: ± 1 PLACE: ± 0.5 0 PLACES: ± DRAFT WHERE APPLICABLE MUST REMAIN WITHIN DIMENSIONS THIRD ANGLE PROJECTION | THIS DRAWING CONTAINS INFORMATION THAT IS PROPRIETARY TO MOLEX ELECTRONIC TECHNOLOGIES, LLC AND SHOULD NOT BE USED WITHOUT WRITTEN PERMISSION | | CURRENT REV DESC: EC NO: 615758 DRWN: UKOWSHIKARAN 2019/04/11 CHK'D: RCG 2019/05/07 APPR: RCG 2019/05/07 | | | |
| | ADAPTER PLATE MFE 48F DSC - BLACK | | PRODUCT CUSTOMER DRAWING | | | |
| | INITIAL REVISION: DRWN: MTAMBRALLI 2012/09/27 APPR: RCG 2013/07/11 | | DOCUMENT NUMBER: SD-18060-052 | DOC TYPE: PSD | DOC PART: 001 | REVISION: C |
| | MATERIAL NUMBER: SEE CHART CUSTOMER: GENERAL MARKET | | SHEET NUMBER: 1 OF 1 | | | |