

NOTES:

1. MATERIAL:
 - A) ADAPTER PLATE: COLD ROLLED STEEL (CRS).
 - B) ADAPTER HOUSING: PBT+FIBERGLASS.
 - C) CAPTIVE SCREW : ZINC PLATED HARDENED CARBON STEEL.
 - D) PHILLIPS PAN HEAD SCREW: GALVANIZED STEEL
 - E) DUST CAP: LDPE
2. FINISH:
 - ADAPTER PLATE : GOTHIC BLACK TEXTURE POWDER COAT.
3. ACCOMODATES 6 LC DPLEX ADAPTERS PER PLATE.
4. ASSEMBLY IS PACKAGED INDIVIDUALLY IN A BOX.
5. DUST CAPS ARE NOT SHOWN. BUT ASSEMBLED TO THE ADAPTERS.

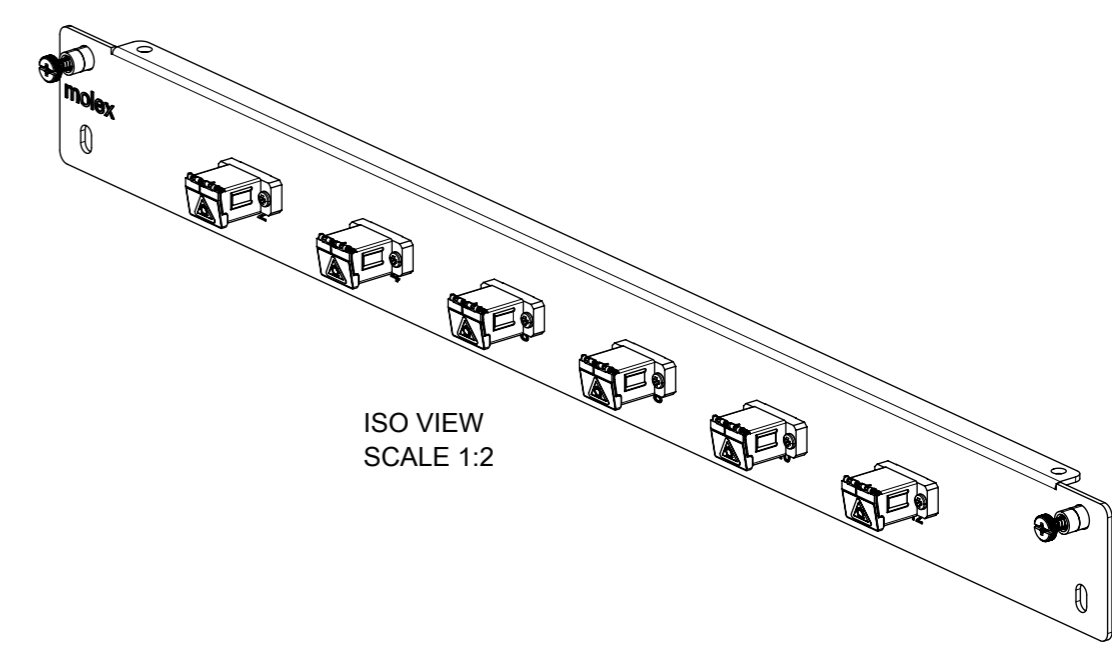
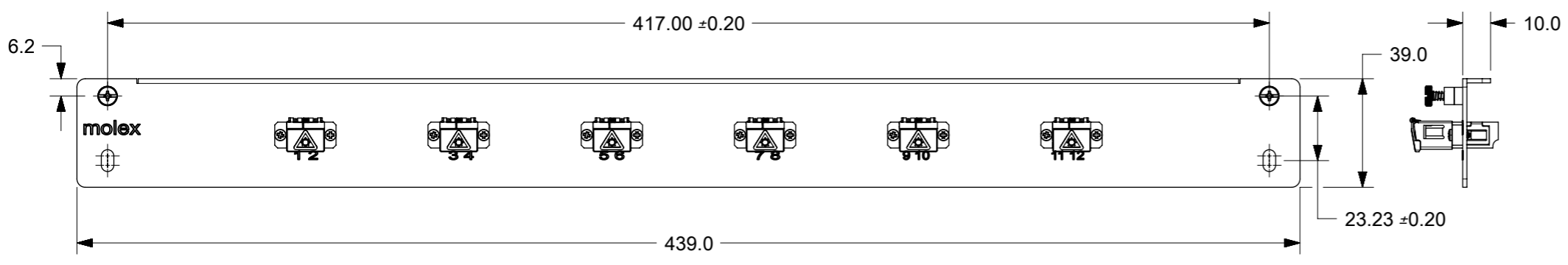

PART NUMBER CHART

MPN NO.	SAP NO.	DESCRIPTION
AFR-00733-BL	180600501	ADAPTER PLATE MFE 12F SM OS1/2 DLC BLU SHTR
AFR-00734-GR	180600502	ADAPTER PLATE MFE 12F SM OS1/2 DLC GRN APC SHTR
AFR-00735-OL	180600503	ADAPTER PLATE MFE 12F MM OM1/OM2 DLC BG SHTR
AFR-00736-AQ	180600504	ADAPTER PLATE MFE 12F MM OM3/OM4 DLC AQ SHTR
AFR-00737-EV	180600505	ADAPTER PLATE MFE 12F MM OM4 DLC EV SHTR
AFR-00700-LG	180600470	ADAPTER PLATE MFE 12F MM OM5 DLC LG SHTR

SYMBOLS	THIS DRAWING CONTAINS INFORMATION THAT IS PROPRIETARY TO MOLEX ELECTRONIC TECHNOLOGIES, LLC AND SHOULD NOT BE USED WITHOUT WRITTEN PERMISSION		CURRENT REV DESC:				
	DIMENSION UNITS	SCALE					
▽ = 0	mm	1:2	EC NO: 615758		PRODUCT CUSTOMER DRAWING		
▽ = 0	GENERAL TOLERANCES (UNLESS SPECIFIED)		DRWN: UKOWSHIKARAN 2019/04/11		DOCUMENT NUMBER		
▽ = 0			CHK'D: RCG 2019/05/07		SD-18060-089		
▽ = 0			APPR: RCG 2019/05/07		DOC TYPE DOC PART REVISION		
▽ = 0			INITIAL REVISION:		PSD 001 C		
▽ = 0			DRWN: MTAMBRALLI 2014/01/25		MATERIAL NUMBER		
▽ = 0			APPR: RCG 2014/02/25		CUSTOMER		
▽ = 0			ANGULAR TOL ± 0.5°		SEE CHART		
▽ = 0	DRAFT WHERE APPLICABLE MUST REMAIN WITHIN DIMENSIONS		THIRD ANGLE PROJECTION		SHEET NUMBER		
▽ = 0			DRAWING A3-SIZE		18060		
▽ = 0			SERIES 18060		GENERAL MARKET		
▽ = 0			MATERIAL NUMBER		1 OF 1		