

NOTES:

1. MATERIAL:
 - A) ADAPTER PLATE: COLD ROLLED STEEL (CRS).
 - B) ADAPTER HOUSING: PBT+FIBERGLASS.
 - C) CAPTIVE SCREW : ZINC PLATED HARDENED CARBON STEEL.
 - D) PHILLIPS PAN HEAD SCREW: GALVANIZED STEEL
 - E) DUST CAP: LDPE
2. FINISH:
 - ADAPTER PLATE : GOTHIC BLACK TEXTURE POWDER COAT.
3. ACCOMODATES 12 LC DPLEX ADAPTERS PER PLATE.
4. ASSEMBLY IS PACKAGED INDIVIDUALLY IN A BOX.
5. DUST CAPS ARE NOT SHOWN. BUT ASSEMBLED TO THE ADAPTERS.

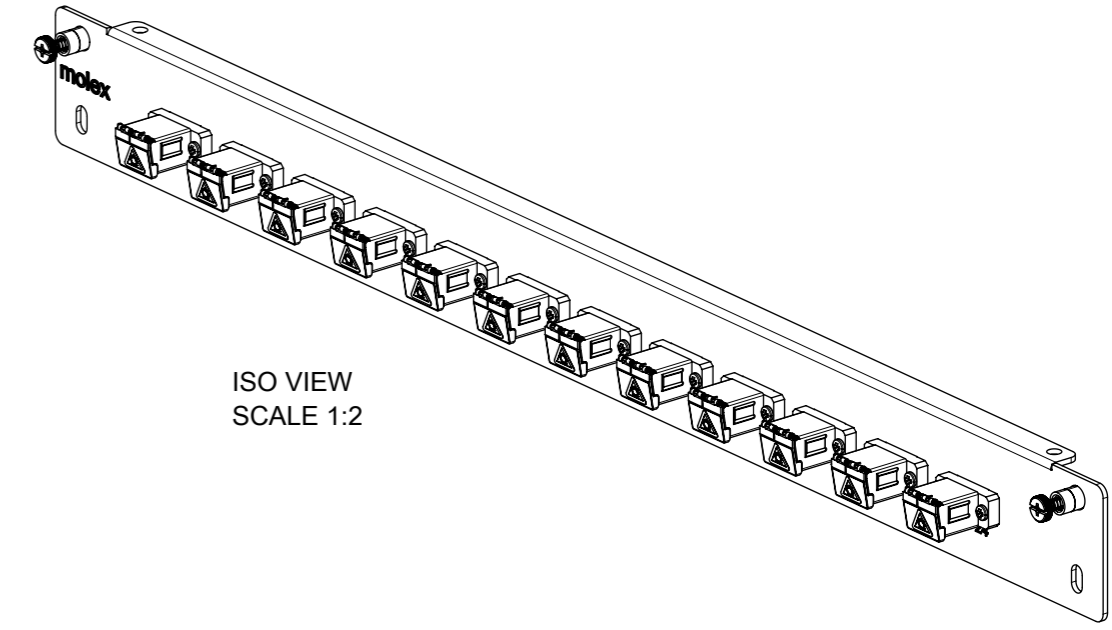
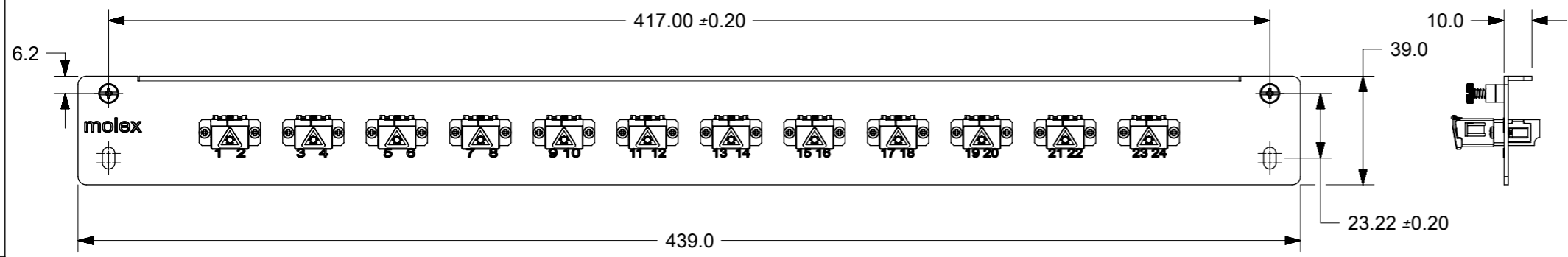
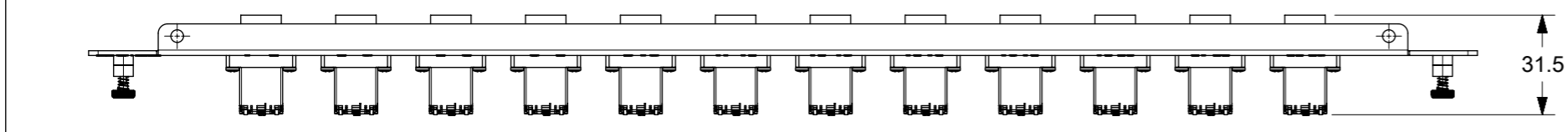

PART NUMBER CHART

MPN NO.	SAP NO.	DESCRIPTION
AFR-00743-BL	180600511	ADAPTER PLATE MFE 24F SM OS1/2 DLC BLU SHTR
AFR-00744-GR	180600512	ADAPTER PLATE MFE 24F SM OS1/2 DLC GRN APC SHTR
AFR-00745-OL	180600513	ADAPTER PLATE MFE 24F MM OM1/OM2 DLC BG SHTR
AFR-00746-AQ	180600514	ADAPTER PLATE MFE 24F MM OM3/OM4 DLC AQ SHTR
AFR-00747-EV	180600515	ADAPTER PLATE MFE 24F MM OM4 DLC EV SHTR
AFR-00702-LG	180600472	ADAPTER PLATE MFE 24F MM OM5 DLC LG SHTR

SYMBOLS		THIS DRAWING CONTAINS INFORMATION THAT IS PROPRIETARY TO MOLEX ELECTRONIC TECHNOLOGIES, LLC AND SHOULD NOT BE USED WITHOUT WRITTEN PERMISSION		CURRENT REV DESC:				
▽ = 0	mm	SCALE	1:2	EC NO: 615758				
▽ = 0	GENERAL TOLERANCES (UNLESS SPECIFIED)		DRWN: UKOWSHIKARAN 2019/04/11		ADAPTER PLATE MFE 24F DLC SHTR-BLACK			
▽ = 0			CHK'D: RCG 2019/05/07					
▽ = 0	4 PLACES ±	MM	INCH	APPR: RCG 2019/05/07		PRODUCT CUSTOMER DRAWING		
▽ = 0	3 PLACES ±			INITIAL REVISION:		DOCUMENT NUMBER		
▽ = 0	2 PLACES ±			DRWN: MTAMBRALLI 2014/01/25		SD-18060-091		
▽ = 0	1 PLACE ±			APPR: RCG 2014/02/25		DOC TYPE DOC PART REVISION		
▽ = 0	0 PLACES ±			ANGULAR TOL ± 0.5°		PSD 001 B		
▽ = 0	DRAFT WHERE APPLICABLE MUST REMAIN WITHIN DIMENSIONS		THIRD ANGLE PROJECTION		DRAWING		MATERIAL NUMBER	
▽ = 0			A3-SIZE		SERIES		CUSTOMER	
				18060		SEE CHART		
						GENERAL MARKET		
						SHEET NUMBER		
						1 OF 1		