

Features

- 12 pins.
- High luminous intensity.
- Low power consumption.
- Wide viewing angle.
- Categorized for luminous intensity.
- Excellent on/off contrast.
- Easy mounting on P.C. board or sockets.
- Solid state reliability.
- RoHS compliant.

Description

The Super Bright Green source color devices are made with Gallium Phosphide Green Light Emitting Diode.

Package Dimensions

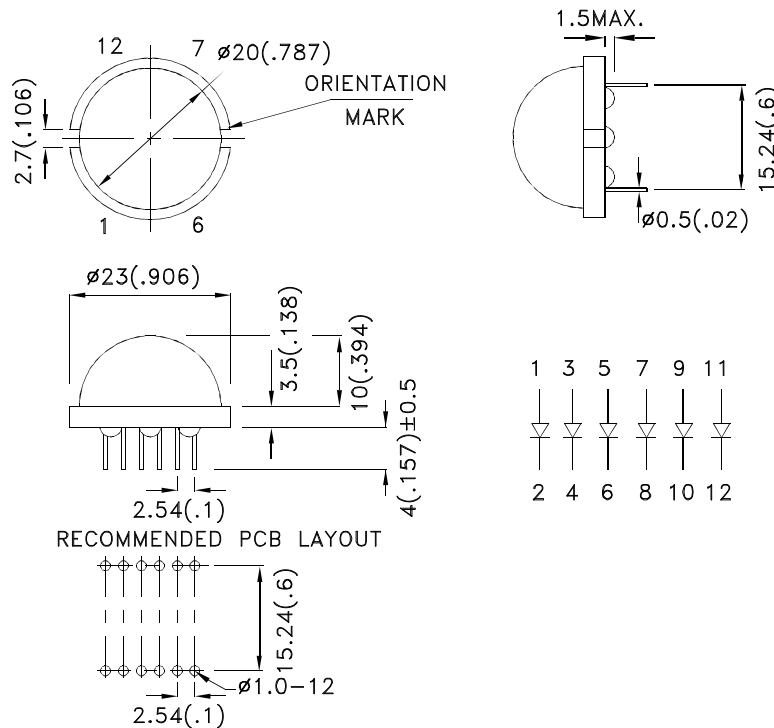

Notes:

1. All dimensions are in millimeters (inches).
2. Tolerance is $\pm 0.25 (0.01)$ unless otherwise noted.
3. Lead spacing is measured where the leads emerge from the package.
4. Specifications are subject to change without notice.



Selection Guide

| Part No. | Dice | Lens Type | Iv (mcd) [2] @ 20mA | | Viewing Angle [1] |
|----------|--------------------------|----------------|------------------------|------|----------------------|
| | | | Min. | Typ. | 2θ1/2 |
| DLA/6SGD | Super Bright Green (GaP) | GREEN DIFFUSED | 70 | 200 | 120° |

Notes:

1. θ1/2 is the angle from optical centerline where the luminous intensity is 1/2 the optical centerline value.
2. Luminous intensity/ luminous Flux: +/-15%.

Electrical / Optical Characteristics at TA=25°C

| Symbol | Parameter | Device | Typ. | Max. | Units | Test Conditions |
|-----------------------|--------------------------|--------------------|------|------|-------|---------------------------|
| λ_{peak} | Peak Wavelength | Super Bright Green | 565 | | nm | I _F =20mA |
| λ_D [1] | Dominant Wavelength | Super Bright Green | 568 | | nm | I _F =20mA |
| $\Delta\lambda_{1/2}$ | Spectral Line Half-width | Super Bright Green | 30 | | nm | I _F =20mA |
| C | Capacitance | Super Bright Green | 15 | | pF | V _F =0V;f=1MHz |
| V _F [2] | Forward Voltage | Super Bright Green | 2.2 | 2.5 | V | I _F =20mA |
| I _R | Reverse Current | Super Bright Green | | 10 | uA | V _R = 5V |

Notes:

- 1.Wavelength: +/-1nm.
2. Forward Voltage: +/-0.1V.

Absolute Maximum Ratings at TA=25°C

| Parameter | Super Bright Green | Units |
|-------------------------------|-----------------------|-------|
| Power dissipation | 62.5 | mW |
| DC Forward Current | 25 | mA |
| Peak Forward Current [1] | 140 | mA |
| Reverse Voltage | 5 | V |
| Operating/Storage Temperature | -40°C To +85°C | |
| Lead Solder Temperature [2] | 260°C For 3-5 Seconds | |

Notes:

1. 1/10 Duty Cycle, 0.1ms Pulse Width.
2. 2mm below package base.



Super Bright Green DLA/6SGD

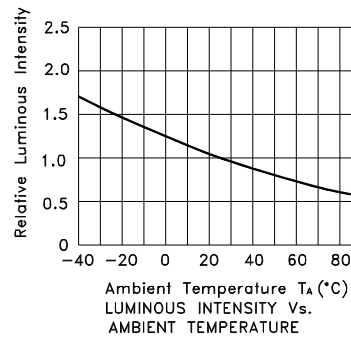
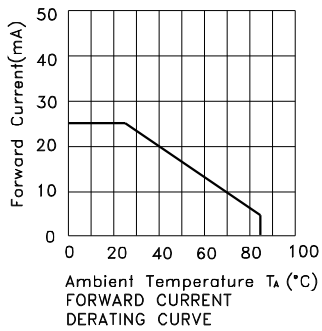
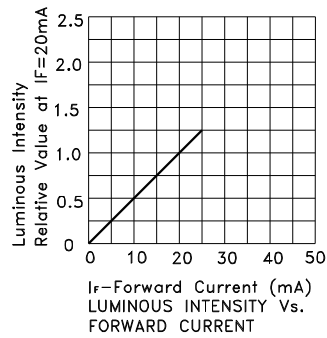
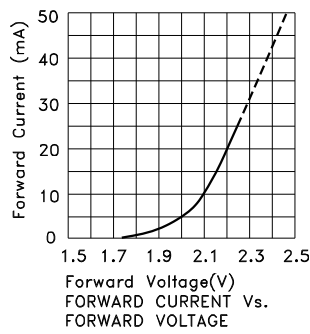

PACKING & LABEL SPECIFICATIONS

DLA/6SGD

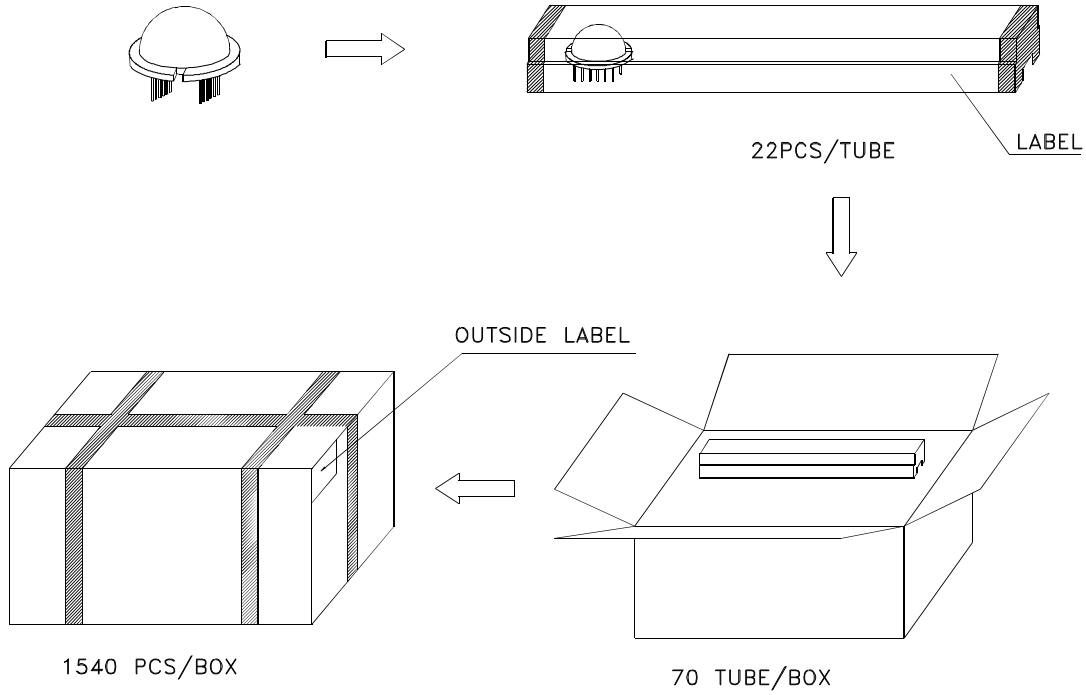

Inside Label Paste On The IC-Tube

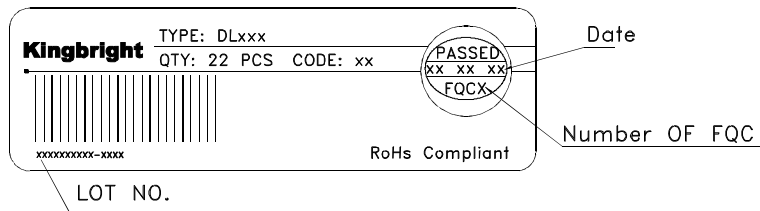

Outside Label Paste On The Box

