

3.5X2.8mm BI-COLOR SURFACE MOUNT LED LAMP

KAA-3528ESGC

UNIT : MM(INCH)

TOLERANCE : $\pm 0.25(\pm 0.01)$

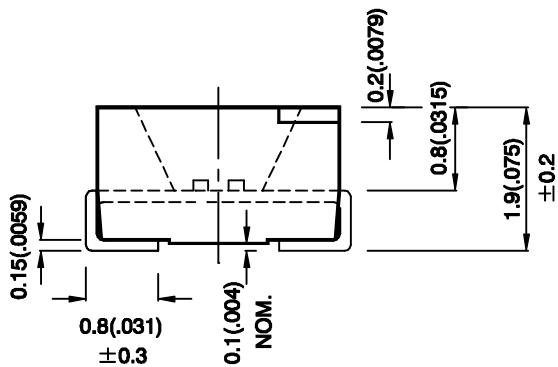
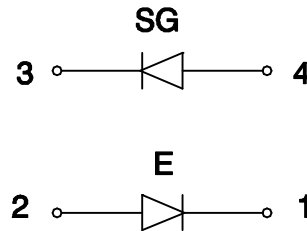
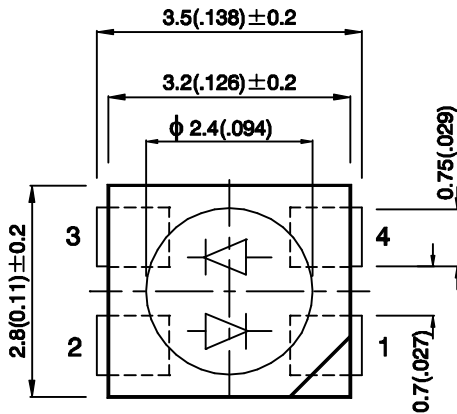

SELECTION GUIDE

PART NO.	SOURCE (DICE)	LENS TYPE (RESIN)	LUMINOUS INTENSITY MCD @10mA		VIEWING ANGLE 2 @ 1/2
			MIN.	MAX.	
KAA-3528ESGC	RED HIGH EFFICIENCY (GaAsP/GaP)	WATER CLEAR	3.2	12.5	120°
	GREEN SUPER BRIGHT (GaP)		3.2	12.5	

APPROVED:

CHECKED:

DRAWN :

SCALE :

DATA NO. : E4463

3 : 1

DATE : OCT/20/98