

## FEATURES AND SPECIFICATIONS

### Features and Benefits

- Crimp terminal for use in all Mini-Fit, Jr., BMI and TPA receptacle housings
- Four gas-tight points of contact on Tin-plated contacts
- HCS offers 3 additional amperes of current

### Reference Information

Packaging: Reel or bag  
 Use With: 5557, 30067 and 42474 housings  
 Designed In: Millimeters

### Electrical

Voltage: 600V  
 Current:  
     Standard—9.0A  
     HCS—12.0A  
 Contact Resistance: 10mΩ max.  
 Dielectric Withstanding Voltage: 1500V  
 Insulation Resistance: 1000 MΩ min.

### Mechanical

Contact Insertion Force: 1.5kg max.  
 Contact Retention to Housing: 3.0kg min.  
 Wire Pull-Out Force: 9.0kg min.  
 Insertion Force to PCB: 5.0kg max.  
 Mating Force: 0.7kg (1.54 lb) max.  
 Unmating Force: 0.35kg (0.7 lb) min.  
 Normal Force: 200g min.  
 Durability: 30 cycles

### Physical

Contact: 5556—Brass or Phosphor Bronze  
           44476—High Copper Alloy  
 \*Plating: See Table  
 Operating Temperature: -40 to 105° C  
 Strip Length: 3.0 (.118) to 3.5mm (.138")

# molex® 4.20mm (.165") Pitch Mini-Fit™ Family Terminal

## 5556/44476 Crimp, Female

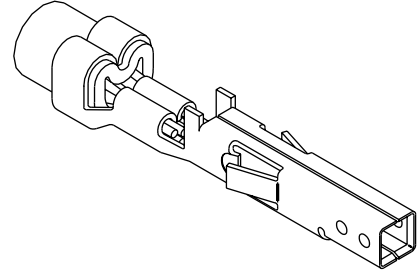

Power Connectors

F

## CATALOG DRAWING (FOR REFERENCE ONLY)

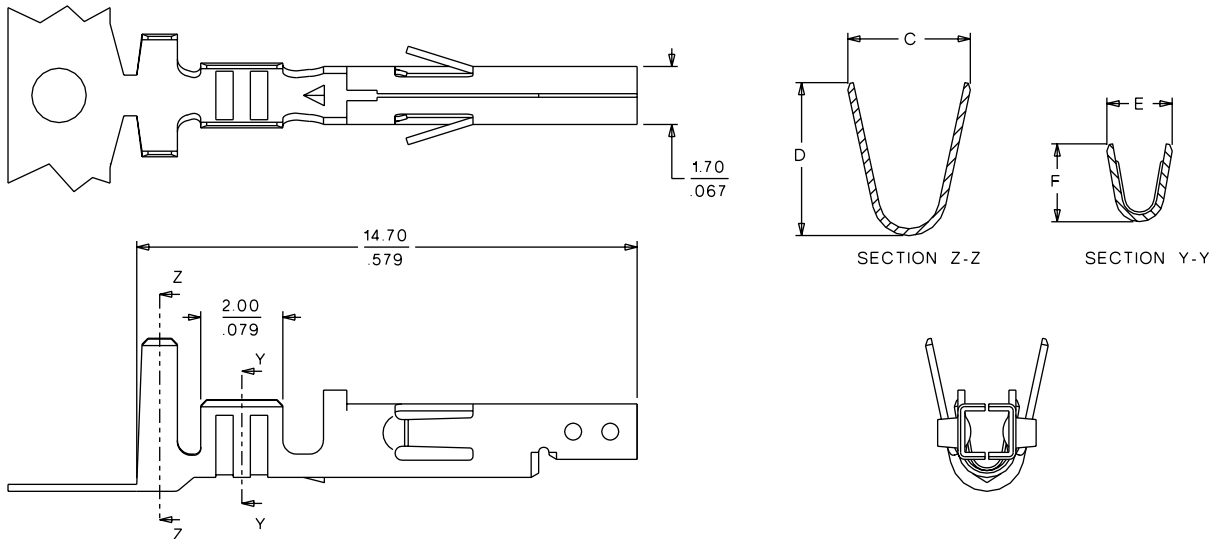

## ORDERING INFORMATION AND DIMENSIONS

Plating*	Wire Size (AWG)	Insulation Range	Order No. 5556		Order No. 44476		Dimension			
			Reel	Bag	Reel	Bag	C	D	E	F
Brass (Pre-plated Tin over Copper)	16	1.80-3.10 (.071-.122)	• 39-00-0077	• 39-00-0078			3.60 (.142)	4.50 (.177)	2.30 (.091)	2.70 (.106)
	18-24	1.30-3.10 (.051-.122)	• 39-00-0038	• 39-00-0039			3.60 (.142)	4.50 (.177)	1.90 (.075)	2.30 (.091)
	22-28	0.90-1.80 (.035-.071)	• 39-00-0046	• 39-00-0047			2.30 (.091)	2.30 (.091)	1.80 (.071)	1.65 (.065)
Brass (Pre-plated Gold over Nickel)	16	1.80-3.10 (.071-.122)	• 39-00-0089	• 39-00-0090			3.60 (.142)	4.50 (.177)	2.30 (.091)	2.70 (.106)
	18-24	1.30-3.10 (.051-.122)	• 39-00-0055	• 39-00-0056			3.60 (.142)	4.50 (.177)	1.90 (.075)	2.30 (.091)
	22-28	0.90-1.80 (.035-.071)	• 39-00-0085	• 39-00-0086			2.30 (.091)	2.30 (.091)	1.80 (.071)	1.65 (.065)
Brass* or Copper† (Post-plated Tin over Nickel)	16	1.80-3.10 (.071-.122)	• 39-00-0211*	• 39-00-0212*	44476-3111	44476-3112	3.60 (.142)	4.50 (.177)	2.30 (.091)	2.70 (.106)
	18-24	1.30-3.10 (.051-.122)	• 39-00-0207*	• 39-00-0208*	44476-1111†	44476-1112†	3.60 (.142)	4.50 (.177)	1.90 (.075)	2.30 (.091)
	22-28	0.90-1.80 (.035-.071)	• 39-00-0209*	• 39-00-0210*			2.30 (.091)	2.30 (.091)	1.80 (.071)	1.65 (.065)
Brass (Post-plated Gold over Nickel)	16	1.80-3.10 (.071-.122)	• 39-00-0167	• 39-00-0168			3.60 (.142)	4.50 (.177)	2.30 (.091)	2.70 (.106)
	18-24	1.30-3.10 (.051-.122)	• 39-00-0163	• 39-00-0164			3.60 (.142)	4.50 (.177)	1.90 (.075)	2.30 (.091)
	22-28	0.90-1.80 (.035-.071)	• 39-00-0165	• 39-00-0166			2.30 (.091)	2.30 (.091)	1.80 (.071)	1.65 (.065)
Phosphor Bronze (Pre-plated Tin)	16	1.80-3.10 (.071-.122)	• 39-00-0079	• 39-00-0080			3.60 (.142)	4.50 (.177)	2.30 (.091)	2.70 (.106)
	18-24	1.30-3.10 (.051-.122)	• 39-00-0059	• 39-00-0060			3.60 (.142)	4.50 (.177)	1.90 (.075)	2.30 (.091)
	22-28	0.90-1.80 (.035-.071)	• 39-00-0065	• 39-00-0066			2.30 (.091)	2.30 (.091)	1.80 (.071)	1.65 (.065)
Phosphor Bronze (Pre-plated Gold over Nickel)	16	1.80-3.10 (.071-.122)	• 39-00-0157	• 39-00-0158			3.60 (.142)	4.50 (.177)	2.30 (.091)	2.70 (.106)
	18-24	1.30-3.10 (.051-.122)	• 39-00-0153	• 39-00-0154			3.60 (.142)	4.50 (.177)	1.90 (.075)	2.30 (.091)
	22-28	0.90-1.80 (.035-.071)	• 39-00-0155	• 39-00-0156			2.30 (.091)	2.30 (.091)	1.80 (.071)	1.65 (.065)
Phosphor Bronze (Post-plated Tin over Nickel)	16	1.80-3.10 (.071-.122)	• 39-00-0217	• 39-00-0218			3.60 (.142)	4.50 (.177)	2.30 (.091)	2.70 (.106)
	18-24	1.30-3.10 (.051-.122)	• 39-00-0213	• 39-00-0214			3.60 (.142)	4.50 (.177)	1.90 (.075)	2.30 (.091)
	22-28	0.90-1.80 (.035-.071)	• 39-00-0215	• 39-00-0216			2.30 (.091)	2.30 (.091)	1.80 (.071)	1.65 (.065)
Phosphor Bronze (Post-plated Gold over Nickel)	16	1.80-3.10 (.071-.122)	• 39-00-0185	• 39-00-0186			3.60 (.142)	4.50 (.177)	2.30 (.091)	2.70 (.106)
	18-24	1.30-3.10 (.051-.122)	• 39-00-0181	• 39-00-0182			3.60 (.142)	4.50 (.177)	1.90 (.075)	2.30 (.091)
	22-28	0.90-1.80 (.035-.071)	• 39-00-0183	• 39-00-0184			2.30 (.091)	2.30 (.091)	1.80 (.071)	1.65 (.065)

\* US Standard Product, available through Molex franchised distributors

† 18 to 20 AWG

\* Tin-plated terminals have 4 points of contact. Gold plated terminals have 2 points of contact.