

FEATURES AND SPECIFICATIONS

Features and Benefits

- Crimp terminal for use in all Mini-Fit, Jr., BMI and TPA plug housings
- Four gas-tight points of contact on Tin-plated contacts
- HCS offers 3 additional amperes of current

Reference Information

Packaging: Reel or bag
Use With: 5559, 42475 and 30068 housings

Electrical

Voltage: 600V
Current:
Standard—9.0A max.
HCS—12.0A max.
Contact Resistance: 10mΩ max.
Dielectric Withstanding Voltage: 1500V
Insulation Resistance: 1000 MΩ min.

Mechanical

Contact Insertion Force: 1.5kg max.
Contact Retention to Housing: 3.0kg min.
Wire Pull-Out Force: 9.0kg min.
Insertion Force to PCB: 5.0kg max.
Mating Force: 0.7kg (1.54 lb) max.
Unmating Force: 0.35kg (0.7 lb) min.
Normal Force: 200g min.
Durability: 30 cycles

Physical

Contact: 5558—Brass or Phosphor Bronze
44478—High Copper Alloy
Plating: See Table
Operating Temperature: -40 to +105°C
Strip Length: 3.0 (.118) to 3.5mm (.138") max.

molex® 4.20mm (.165") Pitch Mini-Fit™ Family Terminal

5558/44478 Crimp, Male

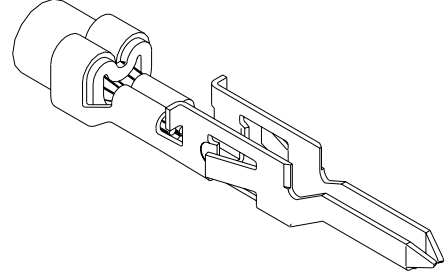

CATALOG DRAWING (FOR REFERENCE ONLY)

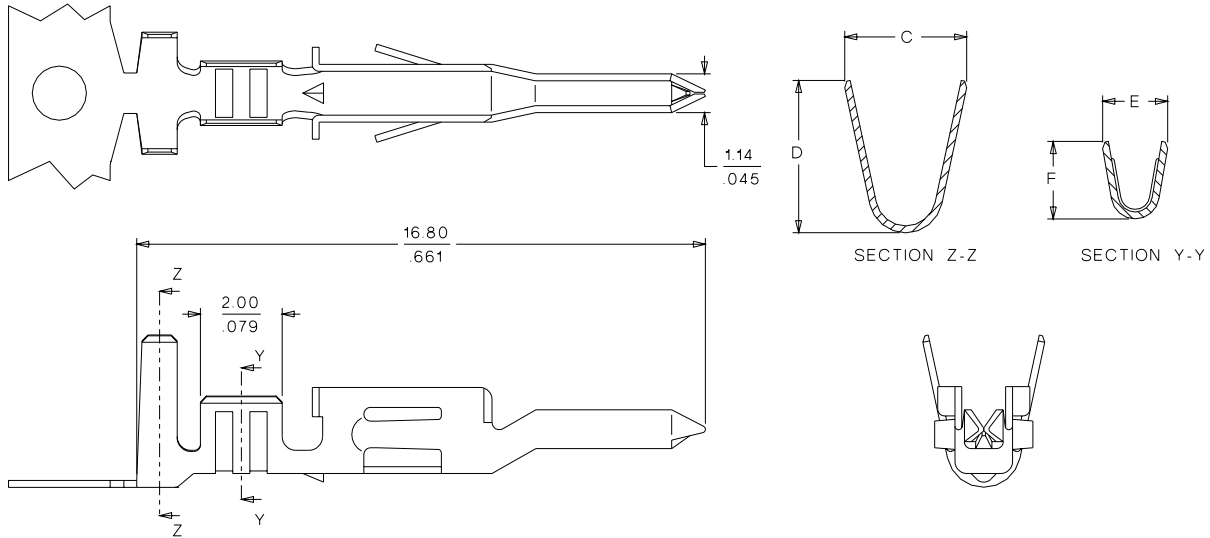

ORDERING INFORMATION AND DIMENSIONS

Plating	Wire Size (AWG)	Order No. 5558		Order No. 44478		Dimension			
		Reel	Bag	Reel	Bag	C	D	E	F
Brass (Pre-plated Tin over Copper)	16	• 39-00-0081	• 39-00-0082			3.60 (.142)	4.50 (.177)	2.30 (.091)	2.70 (.106)
	18-24	• 39-00-0040	• 39-00-0041			3.60 (.142)	4.50 (.177)	1.90 (.075)	2.30 (.091)
	22-28	• 39-00-0048	• 39-00-0049			2.30 (.091)	2.30 (.091)	1.80 (.071)	1.65 (.065)
Brass (Pre-plated Gold over Nickel)	16					3.60 (.142)	4.50 (.177)	2.30 (.091)	2.70 (.106)
	18-24					3.60 (.142)	4.50 (.177)	1.90 (.075)	2.30 (.091)
	22-28					2.30 (.091)	2.30 (.091)	1.80 (.071)	1.65 (.065)
Brass* or Copper† (Post-plated Tin over Nickel)	16	• 39-00-0124*	• 39-00-0125*	44478-3111	44478-3112	3.60 (.142)	4.50 (.177)	2.30 (.091)	2.70 (.106)
	18-24	• 39-00-0120*	• 39-00-0121*			3.60 (.142)	4.50 (.177)	1.90 (.075)	2.30 (.091)
	22-28	• 39-00-0122*	• 39-00-0123*	44478-1111‡	44478-1112‡	2.30 (.091)	2.30 (.091)	1.80 (.071)	1.65 (.065)
Brass (Post-plated Gold over Nickel)	16	• 39-00-0095	• 39-00-0096			3.60 (.142)	4.50 (.177)	2.30 (.091)	2.70 (.106)
	18-24	• 39-00-0053	• 39-00-0054			3.60 (.142)	4.50 (.177)	1.90 (.075)	2.30 (.091)
	22-28	• 39-00-0087	• 39-00-0088			2.30 (.091)	2.30 (.091)	1.80 (.071)	1.65 (.065)
Phosphor Bronze (Pre-plated Tin)	16	• 39-00-0083	• 39-00-0084			3.60 (.142)	4.50 (.177)	2.30 (.091)	2.70 (.106)
	18-24	• 39-00-0061	• 39-00-0062			3.60 (.142)	4.50 (.177)	1.90 (.075)	2.30 (.091)
	22-28	• 39-00-0067	• 39-00-0068			2.30 (.091)	2.30 (.091)	1.80 (.071)	1.65 (.065)
Phosphor Bronze (Pre-plated Gold over Nickel)	16					3.60 (.142)	4.50 (.177)	2.30 (.091)	2.70 (.106)
	18-24					3.60 (.142)	4.50 (.177)	1.90 (.075)	2.30 (.091)
	22-28					2.30 (.091)	2.30 (.091)	1.80 (.071)	1.65 (.065)
Phosphor Bronze (Post-plated Tin over Nickel)	16	• 39-00-0130	• 39-00-0131			3.60 (.142)	4.50 (.177)	2.30 (.091)	2.70 (.106)
	18-24	• 39-00-0126	• 39-00-0127			3.60 (.142)	4.50 (.177)	1.90 (.075)	2.30 (.091)
	22-28	• 39-00-0128	• 39-00-0129			2.30 (.091)	2.30 (.091)	1.80 (.071)	1.65 (.065)
Phosphor Bronze (Post-plated Gold over Nickel)	16	• 39-00-0223	• 39-00-0224			3.60 (.142)	4.50 (.177)	2.30 (.091)	2.70 (.106)
	18-24	• 39-00-0219	• 39-00-0220			3.60 (.142)	4.50 (.177)	1.90 (.075)	2.30 (.091)
	22-28	• 39-00-0221	• 39-00-0222			2.30 (.091)	2.30 (.091)	1.80 (.071)	1.65 (.065)

* US Standard Product, available through Molex franchised distributors
‡ 18-20 AWG